

# THE NO. 5 CROSSBAR DIAL TELEPHONE SYSTEM

*Telephone Systems Training*

**COURSE: CENTRAL OFFICE EQUIPMENT**

LESSON NO. 5B

*Issued January, 1951*

*Reissued July, 1953*



*Western Electric Company*  
INCORPORATED  
HAWTHORNE WORKS

*Industrial Relations Branch*

*Training Department*

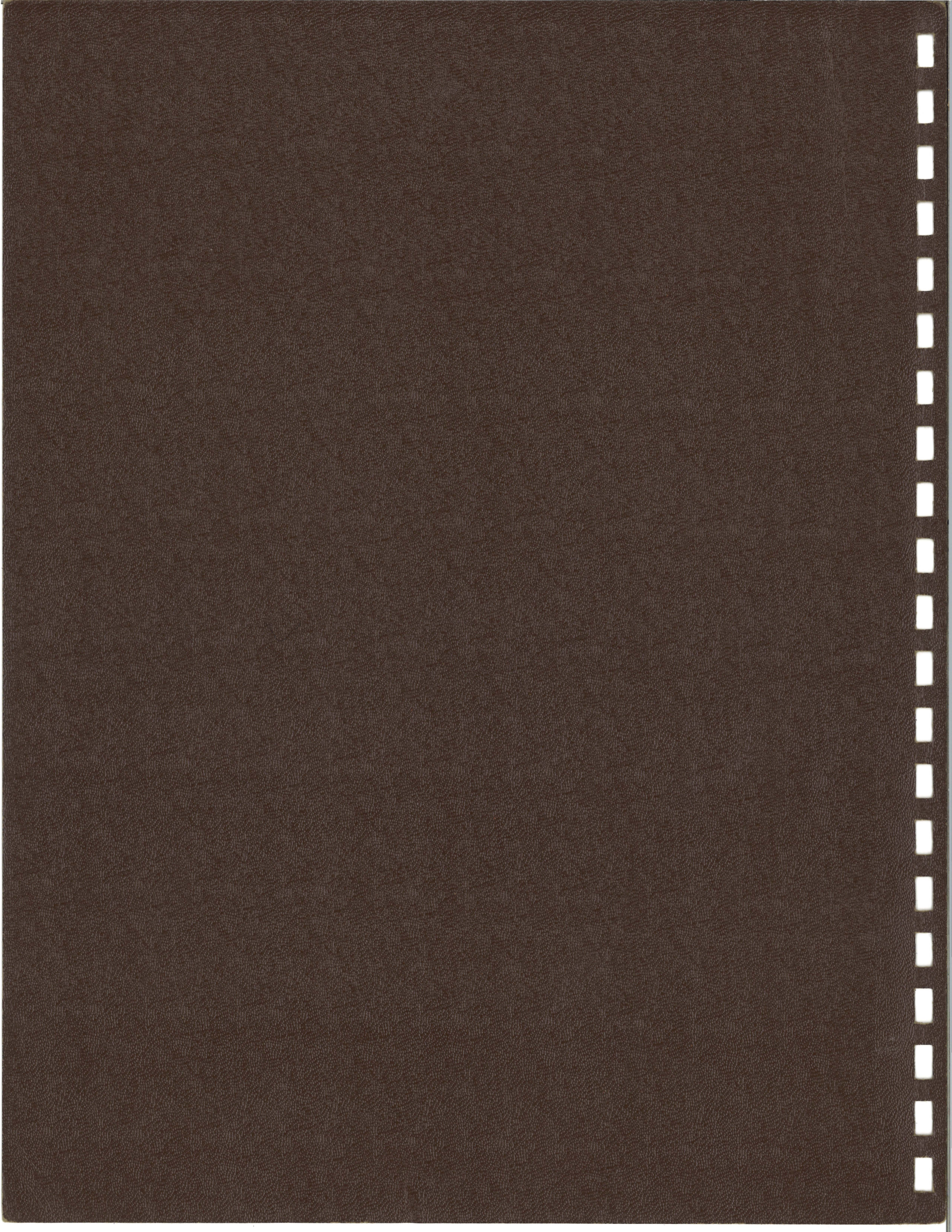

Western Electric Company, Inc.  
Hawthorne Works  
Industrial Relations Branch  
Training Department

Telephone Systems Training  
Course: Central Office Equipment

C. LAMBROU  
1246-4 EX. 351

Lesson No. 5-B

THE NO. 5 CROSSBAR DIAL TELEPHONE SYSTEM

This lesson is issued to describe the general features of the No. 5 Crossbar Dial Telephone System. Information contained herein is to be used for training purposes only.

CONTENTS

- Chapter 1. History and Development.
- Chapter 2. Principles of Dial Switching
- Chapter 3. Equipment.
- Chapter 4. Frames.
- Chapter 5. Operating Features.
- Chapter 6. Method of Operation.
- Chapter 7. Power.

BIBLIOGRAPHY

Bell System Publications



# C O N T E N T S

Page

## Chapter I. History and Development

Section 1	Crossbar No. 1 System - - - - -	1
Section 2	Crossbar No. 5 System - - - - -	1

## Chapter II. Principles of Dial Switching

Section 1	Switching Requirements - - - - -	2
Section 2	Switching of Subscriber Lines - - - - -	2
Section 3	Trunk Switching - - - - -	3
Section 4	Switching by Indirect Control - - - - -	4
Section 5	Switching with Crossbar Equipment - - - - -	5

## Chapter III. Equipment

Section 1	Crossbar Switch - - - - -	6
Section 2	Multi-contact Relay - - - - -	9
Section 3	Multi-contact Switch - - - - -	10
Section 4	The U, UA, UB, and Y Type Relay - - - - -	10
Section 5	The 275 and 276 Type Mercury Contact Relay - - - - -	12
Section 6	The 235 Type Thermal Relay - - - - -	12
Section 7	The Varistor - - - - -	13
Section 8	Vacuum Tubes - - - - -	15
Section 9	Registers - - - - -	16
Section 10	Filters - - - - -	17
Section 11	Networks and Contact Protection - - - - -	18

## Chapter IV. Frames

Section 1	General - - - - -	19
Section 2	Line Link (LL) Frames - - - - -	23
Section 3	Trunk Link (TL) Frames - - - - -	26
Section 4	Extension Trunk Link (ETL) Frames - - - - -	26
Section 5	Marker (M) Frames - - - - -	27
Section 6	Register (OR and IR) Frames - - - - -	28
Section 7	Pretranslator (PRT) Frames - - - - -	31
Section 8	Outgoing Sender (OS) Frames - - - - -	33
Section 9	Inter-Marker Group Sender (IMGS) Frames - - - - -	34
Section 10	B Sender and Position Finder (SPF) Frames - - - - -	34
Section 11	Incoming Register Link (IRL) Frames - - - - -	35
Section 12	Coin Supervisory Link (CSL) Frames - - - - -	35
Section 13	Outgoing Sender Link (OSL) Frames - - - - -	36
Section 14	Trunk Relay Rack (RR) Frames - - - - -	37
Section 15	Number Group (NG AND TNG) Frames - - - - -	37
Section 16	Master Test (MTF) Frames - - - - -	38
Section 17	Connector Frames - - - - -	40
Section 18	Originating Register Marker Connector (ORMC) Frames - - - - -	43
Section 19	Incoming Register Marker Connector (IRMC) Frames - - - - -	43
Section 20	Line Link Marker Connector (LLMC) Frames - - - - -	43
Section 21	Trunk Link Connector (TLC) Frames - - - - -	45
Section 22	Line Link Connector (LLC) Frames - - - - -	45
Section 23	Number Group Connector (NGC) Frames - - - - -	45
Section 24	Outgoing Sender Connector (OSC) Frames - - - - -	45
Section 25	Master Test Connector (MTC) Frames - - - - -	46

## Chapter V. Operating Features

Section 1	General - - - - -	47
Section 2	General Switching Plans - - - - -	47
Section 3	Circuit Features - - - - -	55

## Chapter VI. Method of Operation

Section 1	The Intra-Office Call - - - - -	56
Section 2	The Reverting Call - - - - -	57
Section 3	The Outgoing Call - - - - -	57
Section 4	The Incoming Call - - - - -	58
Section 5	The Tandem or Toll Completing Call - - - - -	60
Section 6	The Inter-Marker Group Call - - - - -	61
Section 7	Message Charging - - - - -	61
Section 8	Test and Trouble Recording Facilities - - - - -	63

## Chapter VII. Power

Section 1	Power - - - - -	79
-----------	-----------------	----



CHAPTER I

HISTORY AND DEVELOPMENT

Section 1. Crossbar No. 1 System.

Experience gained during the past 10 years in connection with the development, manufacture, installation and maintenance of the existing Crossbar No. 1 Dial Telephone System has resulted in further application of the crossbar switching mechanism to the problems of toll switching in Crossbar No. 4, of tandem switching in Crossbar Tandem, and now to the problems of fringe area switching in the Crossbar No. 5 System. The advantages of the crossbar switching principle, which include the flexibility afforded by common control circuits and the accessibility of lines and trunks to each other recommend this switching principle to further application in the Crossbar No. 5 System.

The first Crossbar No. 1 Dial System central office was the Troy Office, installed on a trial basis for the New York Bell Telephone Company in Brooklyn, New York, and placed in actual service on February 13, 1937. Many succeeding central offices have been installed throughout the Bell System including offices in Lynn, Massachusetts; New York City; Washington, D.C.; Chicago, Illinois; Detroit, Michigan; Seattle, Washington; and Alameda, California. To date, over 100 thousand frames have been manufactured and installed and are now satisfactorily serving approximately 5 million lines.

Section 2. Crossbar No. 5 System

The development of nationwide operator toll dialing and extended customer toll dialing of calls has revealed the need for a central office switching system capable of serving as both a local central office and an intertoll-intertandem office which, in the process of serving the latter must be capable of operating directly with all present local, tandem and toll systems. The Crossbar No. 5 System is particularly well suited to these requirements of nationwide dialing as applied to local exchange areas on the fringes of large cities. Such areas require a system capable of operating with a great variety of other offices including Manual magneto, Manual common battery, Panel, Step-by-Step, Crossbar No. 1, Crossbar No. 4, Sender Tandem and Crossbar Tandem.

The trial installation of a Crossbar No. 5 System was made at Media, Pennsylvania and placed in service July 11, 1948, followed by other installations in the New York City, Washington D.C., and Chicago, Illinois areas in 1949.

CHAPTER II

PRINCIPLES OF DIAL SWITCHING

Section 1. Switching Requirements

The function of any telephone switching system is to connect the lines of any two of the subscribers so that they may talk over the electrical circuit thus established. The term line, or subscriber line when used in telephone work is defined as a talking path, usually two wires, which is terminated at one end in a subscribers instrument and at the other end in the central office switching equipment. The requirements of any system serving originating calls are that each subscriber line in an office have access to all trunks outgoing from that office. The similar requirements of a system serving terminating calls are that each trunk incoming to an office have access to all subscriber lines in that office. The term trunk when used in the telephone work is defined as a talking path, usually two wires, between two central offices and terminated in switching equipment at each office.

Section 2. Switching of Subscriber Lines

In a manual telephone system the subscriber orally transmits the number he desires to an operator who selects the number for him and connects his line to the line of that number or who, in larger systems, connects his line with a trunk to the called office and repeats the number desired to another operator who in turn completes the connection from the trunk to the called line. In a dial system the operator is eliminated insofar as local calls are concerned but the sequence of operations is somewhat similar, with the operations being performed by electro-mechanical switches.

Since an electro-mechanical switch cannot respond to the voice of the subscriber as an operator can, each subscriber station equipment includes a dial by means of which he transmits electrically the number he is calling. Actually when the dial is operated by a calling subscriber the electrical circuit between the subscriber and the central office is opened and closed a certain number of times depending upon the letter or number dialed. For example, if number 4 is dialed the circuit is opened and closed 4 times thus generating 4 pulses which transmit definite information to the mechanical equipment in the central office.

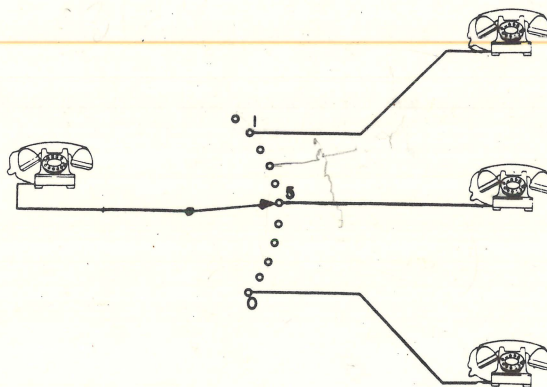

Fig. 1-A Simple Dial Telephone System

The simplest form of a dial telephone system (Fig. 1) would be some form of an electro-magnetic switch connected to the subscriber line, the selector arm of which could by means of an electro-magnet be moved one step each time the circuit of the subscriber line was broken and remade by the operation of the dial. This would enable the subscriber to connect his telephone to any one of a group of telephones by a single rotation of the dial. For instance, by dialing one (1) the telephone connected to the first contact of the switch would be selected; by dialing five (5) the telephone connected to the fifth contact would be selected. As many telephones could be selected by the one switch as there were contacts on that switch.

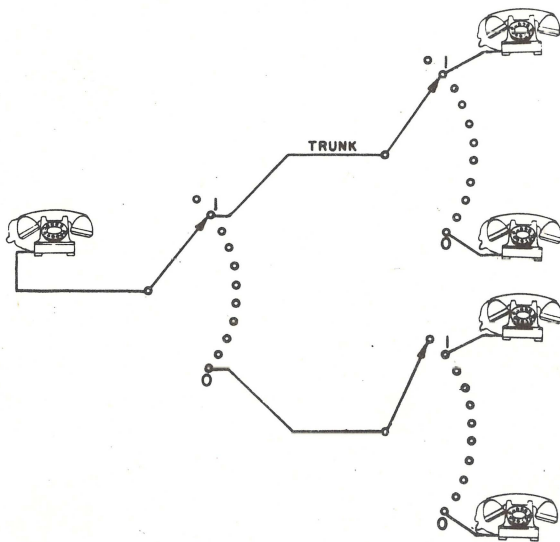

Fig. 2 - Another Dial Telephone System

More telephones could be reached by the subscriber through the use of additional switches arranged as in Fig. 2. Here the first rotation of the subscriber dial sends out pulses which cause the selector arm of the first switch, located in the calling party's central office, to move and connect to a path, or trunk to a second switch, located in the called party's central office. The second rotation of the dial operates the selector arm of the second switch. To insure that the second switch is operated by the second rotation of the dial, and the first switch is not moved, a slow release relay is included in the circuit. This relay is so slow that it will not release between the rapid pulses produced by the dial, but it will release in the pause which ensues while the subscriber reaches for the second pull of the dial. This slow release relay involves a fundamental principle of Dial Telephone Systems which makes it possible for the telephone switching equipment to accept information in the form of successive trains of pulses and to sort out those trains for the individual use of various portions of the switching equipment.

The two arrangements thus far described allow for only one telephone to originate calls to any of the others. In order that the other telephones may originate calls also, it is necessary to equip each telephone with a selector switch of its own. During the time that the subscriber is not using his telephone for an outgoing call this switch, of course, would be idle. This condition would be wasteful of switches and space, and can be eliminated by introducing a switch known as a "line finder". One of these line finder switches is provided for a group of subscriber lines, the lines being connected to the terminals of the switch bank. The term bank as used in telephone work is defined as an assembly of terminals arranged in horizontal rows and in vertical columns of these rows and capable of connection to a selector arm or brush. The switch is so designed that when a subscriber lifts his receiver, the selector arm automatically rotates and finds the calling subscriber line terminal and makes contact with it. This connects the subscriber line to a first selector switch, via the line finder, and the operation of the dial causes the called line to be selected the same as in the system previously described. Fig. 3 represents a complete telephone system, which operates on this principle. This system includes a line finder switch which connects the calling subscriber line circuit with one of the first selector switches. The first selector switches are shown connected by means of trunks, to the second selector switches. After the line finder switch has connected the calling subscriber telephone to the selecting equipment, the first selector, under control of the first dialing, selects a trunk to the desired office (it may be the same office in which the called subscriber line is connected). The trunk connects to a second switch, in the called office, which is controlled by the second dialing to select a path to the group of telephones wanted. This group of telephones is connected to a third switch known as a connector switch. The third dialing causes the selected path to be connected to one of these lines, completing the connection between the calling and the called telephones.

### Section 3. Trunk Switching

An additional feature is illustrated in Fig. 3. It will be noted that there are two trunks between office "A" and office "B" and that these trunks are multiplied to both of the first selector switches shown. Thus, two subscribers may at the same moment talk from office "A" to office "B", but this requires an additional feature in the selector switches. Each must be so arranged that if it is moved by a subscriber dialing to a trunk which is already in use, it will automatically move to the next trunk. This feature is known as "trunk hunting" and is characteristic of dial telephone systems of this type. In such systems the number of trunks in any group over which a selector can hunt is generally limited to 10 by the mechanical dimensions of the switch and by the decimal number system employed in dialing. Where more than 10 trunks are required, they must be divided into two or more groups, each of which does not exceed ten (10).

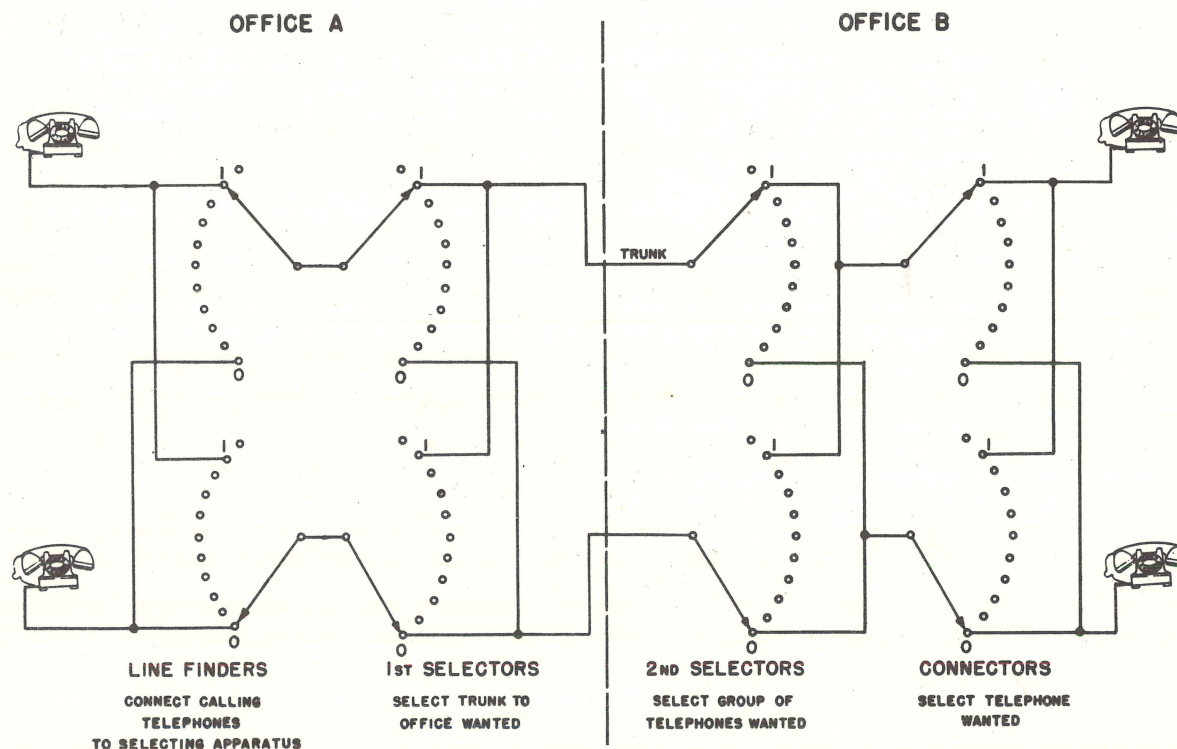

Fig. 3 - Dial Telephone System Using Line Finders

If all trunks in one of these small groups of 10 become busy, a selector hunting in that group will not be able to complete the call although there might still be idle trunks in another group. Could all of these trunks be put in one group so that each selector could hunt over all of them it would always be possible for each selector to complete a call so long as any trunk was idle. One group of 20 trunks will in this way handle more than twice as much traffic as two groups of 10 trunks. Where a large number of trunks is required to each office, the advantages of equipment so constructed that the selector can hunt over large groups of trunks are apparent. The realization of this, coupled with the fact that trunking systems in the larger cities are necessarily complex, was largely responsible for the development of the panel dial type Selector consisting of brushes attached to a rod moving over banks of subscriber or trunk terminals. The Panel Dial System equipment is so constructed that the selector may hunt over a group of trunks as large as 90 if desired or any lesser number required for efficient service.

#### Section 4. Switching by Indirect Control

It is necessary to abandon direct control by the subscriber dial, which is equipped with only 10 pulsing positions, when trunk groups of over 10 are used or when a bank of terminals is divided into a variable number of trunk groups with a variable number of trunks in each group. The time interval required in moving a selector over a group of 90 trunks becomes so great that it will exceed the interval between the dialing of two digits, and the second digit would be dialed before the first had been registered in the selector. In addition to the abandonment of direct control it is necessary in such a large and complicated installation as that required in a large city to abandon also numerical selectors so that any group of trunks in an office may be associated with any dialing combination which may be desirable from a traffic standpoint. Having abandoned direct control and numerical selection, the digits which the subscriber dials have no direct relation to the group of trunks with which these various combinations of digits are associated.

The Panel Dial System provides a system of selectors, switches, and relays arranged in proper combinations which will receive the dialing from the subscriber, record it, and decode it in such a way as to operate certain combinations of these components, which will in turn control circuit closures to complete calls from one subscriber to another.

Section 5. Switching with Crossbar Equipment

The Crossbar No. 1 Dial System, designed to replace the Panel Dial System is also of the indirect control type and consists essentially of crossbar switches and multi-contact relays instead of panel dial selectors and sequence switches. The crossbar switch is the principle switching element consisting primarily of horizontal and vertical circuits each under magnetic control. A large number of contact combinations are available with this arrangement by means of which one of a number of paths may be selected and established through a switch unit. A path is completed when a point on a vertical circuit is connected to a point on a horizontal circuit, the number of these cross points available being determined by the number of horizontal and vertical circuits. Crossbar switches commonly have ten (10) horizontal circuits and either 10 or 20 vertical circuits.

The crossbar switching principle is also applied to toll switching in the Crossbar No. 4 Dial System and to tandem switching in the Crossbar Tandem System. Further, application of the crossbar switching principle to the serving of fringe areas around large cities is now accomplished in the Crossbar No. 5 Dial System.

Fig. 4 shows the sequence of equipment involved in completing a call through a Crossbar No. 5 Dial Central Office. The line link and trunk link frames carry the talking connection, while the remaining frames are used only in completing the call from the time of dialing to when the two subscribers may start conversation. Each line link frame may handle a maximum of 100 simultaneous connections and each trunk link frame a maximum of 160 simultaneous connections. The number of frames required, on an installation of less than the maximum possible size for the system, will be determined by the number of simultaneous connections required during the hour of peak traffic.

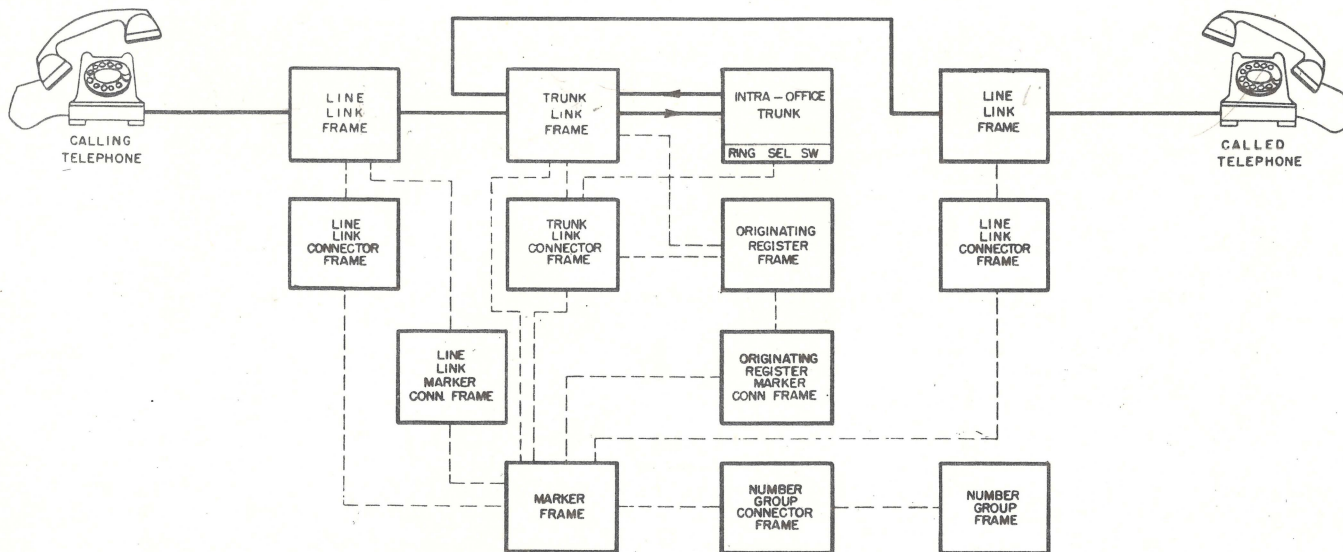

Fig. 4 - The Equipment Involved in Completing a Call Between Two Subscribers in the Same Crossbar No. 5 Central Office

CHAPTER 3

EQUIPMENT

Section 1. Crossbar Switch

The crossbar switch (Fig. 5 and 6) is the principle line and trunk switching device used in crossbar system talking paths and may be described as a selective multi-unit two stage relay, referring to the fact that two or more units of the switch may be selected for simultaneous use and this selection must be performed in two stages. The crossbar switch consists of a rectangular field of contact springs arranged in ten horizontal rows and either ten or twenty vertical rows operated by horizontal and vertical bars. Any set of contacts may be closed by the operation of a horizontal bar, which determines the horizontal row, followed by the operation of a vertical bar which operates the contacts. These operations constitute the two stages of selection of a particular set of contacts, known as crosspoints because the particular set operated will be those located at the crossing point of the horizontal and vertical bars. Contacts thus established remain operated under control of the vertical bar, the horizontal bar being permitted to release.

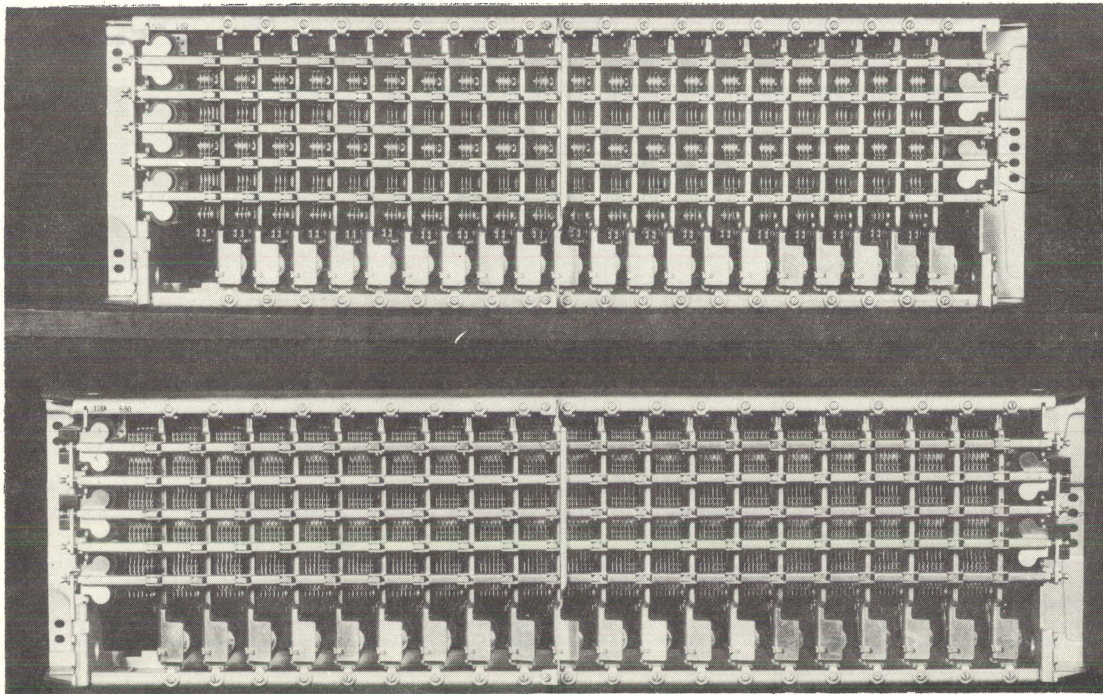

Fig. 5 - 200 Point Crossbar Switches (Front View)

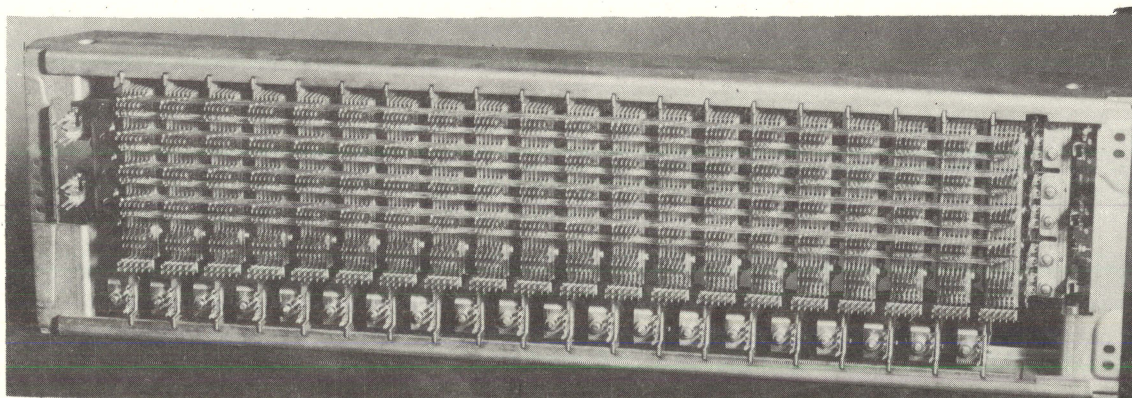

Fig. 6 - 200 Point Crossbar Switch (Rear View)

The horizontal bars and attached flexible wire fingers are known as the selecting elements of the crossbar switch (Fig. 7). Each selecting bar, of which there are five on each switch, is arranged to be partially rotated on its axis in either direction by one of two select magnets associated with that selecting bar. Each of the five selecting bars on a switch may thereby either raise or lower its attached set of selecting fingers to select one of the ten horizontal rows of contacts.

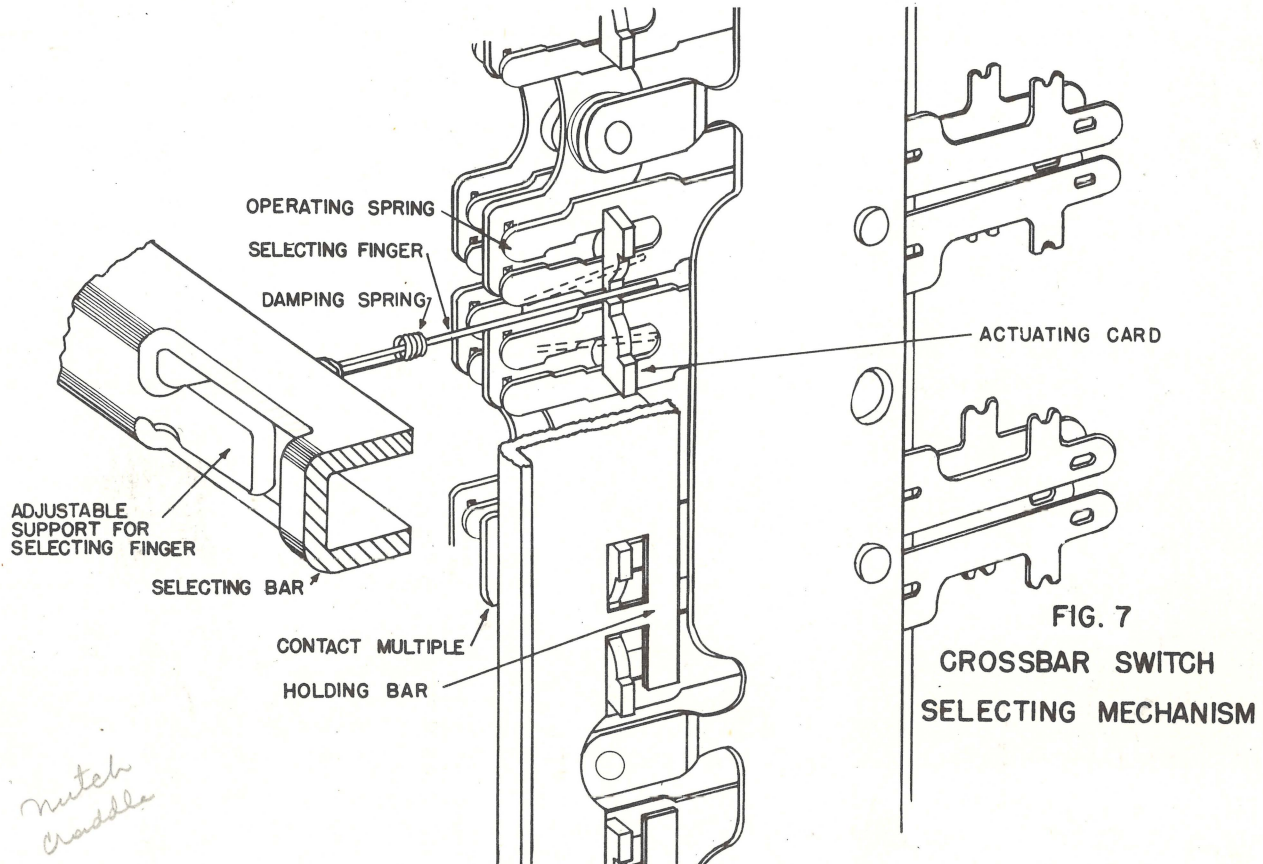

Fig. 7 - Crossbar Switch Selecting Mechanism

The vertical bars are part of a vertical unit assembly having ten sets of relay-like contact springs (Fig. 8). Each set consists of three or six pairs of normally open or "make" contact springs. One spring of each pair is a fixed spring consisting of a projection on an insulated vertical metal strip made in the shape of a comb. This strip extends from the top to the bottom set of contacts of a vertical row, the fixed springs resembling the teeth of the comb. The wiring lug is provided at its lower end, and projects to the rear for connection to cable. At the lower end of the strip and facing the front is another projection which serves as a jack for test and make busy purposes. This metal strip thus provides a continuous and self-contained multiple within the vertical unit assembly for alternate vertical rows of spring contacts. The remaining or mate spring of each pair is individual to each of the ten sets of contacts in a vertical unit and is insulated from all other springs. These mate springs extend to the rear of the switch for wiring purposes. The soldering terminals, in addition to being arranged for individual wiring, also have notched projections to permit the use of bare wire strapping where it is desired to multiple the individual contacts of two or more vertical units in a continuous horizontal circuit. The individual, or operating, springs are made of much lighter material than the fixed springs and are the springs which will be moved by the vertical bar to close contact with the fixed springs. These operating springs have bi-furcated (two forked) ends, each fork of a spring being equipped with a precious metal contact, while the single projection on the common metal strip constitutes the fixed or stationary spring of the pair and mounts two precious metal contacts for each circuit closure.

The vertical bar portion of each vertical unit assembly is known as a holding bar and is part of a long vertical armature pivoted so as to rotate under control of a holding magnet and a restoring spring. Operation of the holding bar alone by the holding

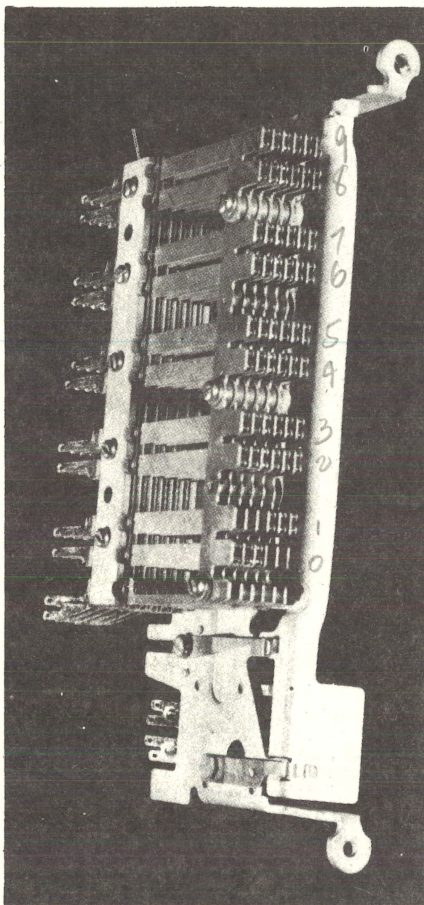

Fig. 8  
Crossbar Switch Vertical Unit

magnet will not actuate the contact spring assemblies, nor will the operation of the selecting bar alone. It requires a two stage operation to effect contact closure at any crosspoint. First, a selecting magnet must be operated and kept energized. Second, the holding magnet of the desired vertical unit must be operated, after which the selecting magnet must be released before the actuating of a new contact spring assembly can be secured. The holding magnet will remain energized throughout the duration of the contact closure. Each spring assembly is equipped on the right with an actuating card which is constructed to act as a stop and limit the vertical travel of the selecting fingers. With the switch normal, one selecting finger is at rest in a horizontal position midway between each pair of spring assemblies. The selecting fingers also occupy positions in a vertical plane between the actuating cards and the holding bars of the various vertical units so that upon the operation of the selecting magnets, the fingers are free to travel up or down within the limits of the stops mentioned and come to rest in the same horizontal plane as the actuating cards and in between the actuating cards and the holding bars. The selecting magnet must remain energized until a holding magnet is operated, so that the selecting finger will be trapped between the holding bar and the actuating card and will cause the selected spring assembly to close its contacts. Upon the release of the selecting magnet the selecting finger remains held between the holding bar and actuating card, and due to the flexible nature of the selecting finger the selecting bar is permitted to return to normal. It may again be operated when it is desired to select any of the crosspoints on other vertical units which are under control of the same selecting bar. The switch may also be equipped with "off normal" spring assemblies which are associated with the selecting and holding magnet and which are operated whenever the associated magnet is energized. When provided they are individual to each magnet and are not dependent upon the two-stage operating cycle described. "Off normal"

spring assemblies are provided when it is necessary to give an electrical signal that a selecting or holding magnet has fully operated its associated selecting or holding bar.

Only one selecting magnet on a switch may be operated at one time if the closing of more than one crosspoint on a vertical unit, with the resulting double connection, is to be avoided. More than one connection throughout a switch may exist at the same time without interference after the crosspoints for each have been closed, but those crosspoints must each be closed one at a time. The selecting magnet used for each crosspoint is released and restored to its normal position shortly after the holding magnet for that connection operates. The wire selecting finger is then clamped in position as long as the holding magnet is operated, and because of its flexibility the wire selecting finger does not interfere with later operation of the selecting bar. Operation of the next crosspoint will start with the operation of a selecting bar and so must wait for the full release of the selecting bar from the previous connection. This handling of one connection at a time in a switch, later extended to handling one call at a time in a frame of switches, is a fundamental operating principal of all crossbar systems. Resulting from the use of this fundamental principal is a freedom from double connections and a necessity for holding to a minimum the time required for a control circuit such as a marker to establish each connection.

The crossbar switch framework is 9-1/4 inches in height and is provided in three lengths; 20-1/2 inches, 30-1/2 inches, and 34-1/2 inches, mounting 10 or 20 three wire and 20 six wire vertical units respectively. The ten vertical unit switch is known as a 100 point switch, containing 100 crosspoints, and is made in 3, 4 and 6 wire sizes. The wire size classification indicates the number of spring pairs at each crosspoint: For example, a 100 point 3 wire switch contains 100 crosspoints, each of which consists of 3 spring pairs, and a 200 point 6 wire switch contains 200 crosspoints, each of which consist of 6 spring pairs. The 20 vertical unit switch is known as a 200 point switch and is made in 3 and 6 wire sizes.

Section 2. Multi-Contact Relay

The use of common control circuits, in crossbar system switching, leads to the necessity of connecting a host of control leads between the control frame and the switching frames during the instant of setting up a connection. The simultaneous connecting of this multitude of leads is done principally by the multi-contact relay (Fig. 9) which resembles in appearance the vertical unit of a crossbar switch. This relay is actually made up of an assembly of two relays on a common mounting, since each half of the relay has its own separate magnet, armature, and spring assemblies. Each assembly may therefore be used as an independent relay, or when desired they may be used as one relay by connecting the two magnet coils in multiple

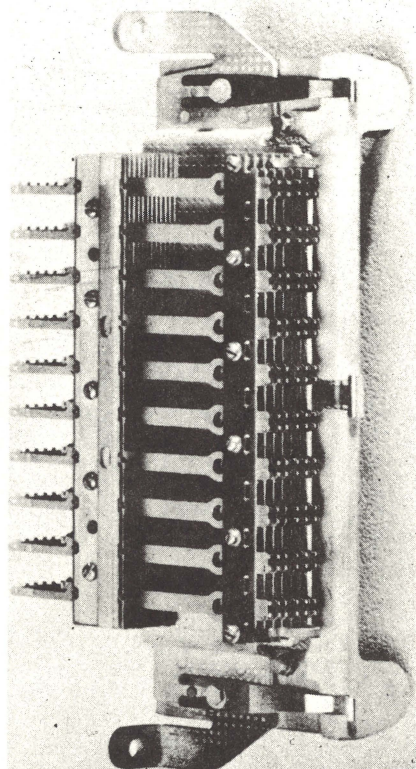

Fig. 9 - Multi-Contact Relay

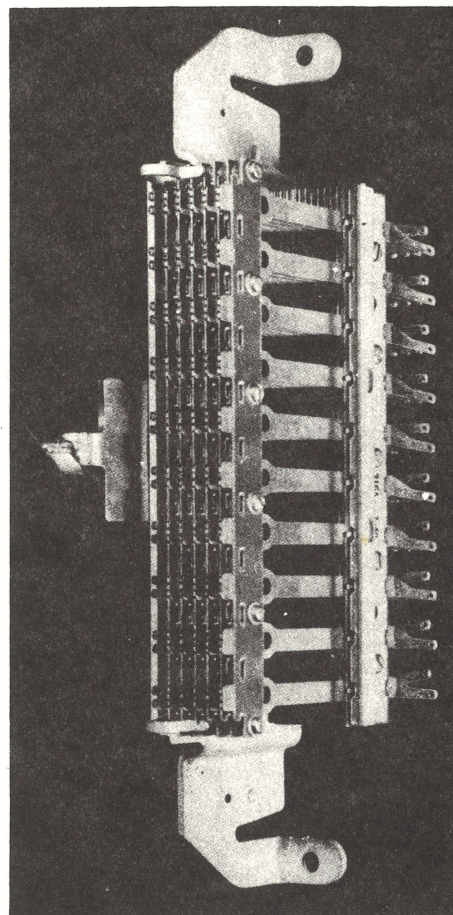

Fig. 10 - Multi-Contact Switch

The spring nests consist of normally open or "make" contacts with all springs brought out individually at the front and rear and with no internal multiplying of contacts. Energizing a magnet operates all springs under control of that magnet and the contacts are closed. All springs have split ends and twin contacts.

The multi-contact relay is available in 4 spring capacities, of 30, 40, 50, and 60 pair of "make" contacts, and when each half of the relay is used separately, spring capacities of 15, 20, 25, and 30, respectively, may be obtained. The relay is mounted with the armatures vertical and occupies a mounting space of approximately 2 inches by 11 inches. A tight fitting can-type cover slips over the spring pile-ups, covering the contacts and leaving the magnets and armatures exposed.

The multi-contact relay is made in two designs; one, the 263 type, is equipped with soldering lugs for common bare-wire strapping between corresponding springs of two or more relays, and the other, the 264 type, arranged for individual wiring only. On the first type, a fiber detail mounted on the soldering lugs guards against accidental shorting of adjacent terminals and also maintains a fixed spacing between the terminals. A specially designed terminal strip, the 218 type, is provided for terminating the multiple strapping and for making the cable connections to that multiple.

Section 3. Multi-Contact Switch

The multi-contact switch (Fig. 10) is used where continuous operation over relatively long periods of time is desired and where the power to operate a multi-contact relay would be an unnecessary waste. It is essentially a multi-contact relay with the magnets omitted and replaced by a lever or key for manually actuating a plate which takes the place of the armatures. This switch is designed in two types, the 216A and B, one with a single lever which will operate all 60 spring sets and the other type having two levers, each of which control half of the spring sets as in the case of the multi-contact relay. The 216A is the only type produced with soldering terminals arranged for individual wiring alone.

Section 4. The U, UA, UB, and Y Type Relay

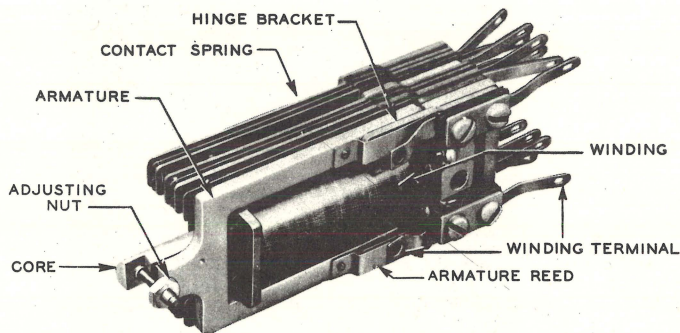

Fig. 11 - U Type Relay

The U type relay (Fig. 11) is an improved general purpose relay, designed with a heavy and more efficient magnetic structure than previous types. It will accommodate up to 24 contact springs (12 upper and 12 lower) each series of 12 being capable of arrangement in any combination of "make" contacts, break contacts, make before break, and etc. The springs are equipped with twin contacts, and the relay has characteristics which make it free from contact chatter. The front ends of the core and armature, and the adjusting nut are chromium plated to reduce any tendency of the armature to "stick" either

against the core or the adjusting nut. The coil is form-wound for a snug fit around the core. Each winding layer is separated by a sheet of cellulose acetate and each sheet is hermetically sealed to the spool head at both ends.

The Y type relay (Fig. 12) is a slow acting U type. Delay of the action is secured by inserting a copper or aluminum sleeve between the core and the winding coil. The armature of the Y relay differs slightly from that of the U in having a small area, raised by embossing, for contact with the core instead of two non-freezing discs. This area provides more definitely controlled air gaps between the armature and core with the relay operated, tending to provide more uniform release-time characteristics.

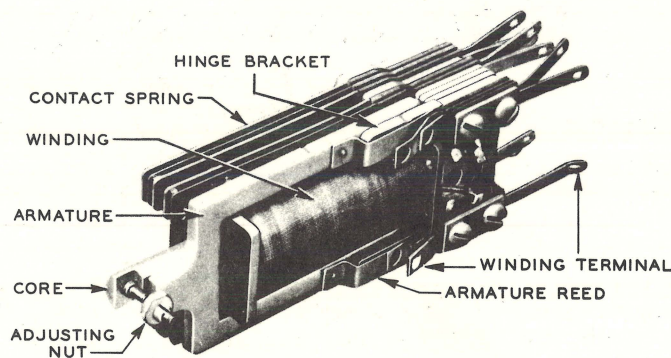

Fig. 12 - Y Type Relay

The UA relay (Fig. 13) differs from the U type in having a much larger pole-face area due to swaging of the core. The enlarged pole-face area and the use of a one-piece armature and hinge bracket of thicker material permit the relay to operate on lower current than is required by the U type. Other differences include the UA type being made up with two diameters of core and two thicknesses of armature.

The small diameter core is usually used with the thinner armature as a combination which produces a very fast releasing relay (Fig. 13). The thicker armature is used with either diameter core for operating a great number of contact springs (Fig. 14). The improved operating characteristic of the UA type relay as compared with the U type relay permit magnetic-iron UA type relays to be used in place of many per-

malloy U type relays and in place of B type relays where sufficient current for operation is available. UA type relays are used for the supervisory relays that supply talking battery in trunk circuits. Individual covers for cross-talk shielding are not required on these relays.

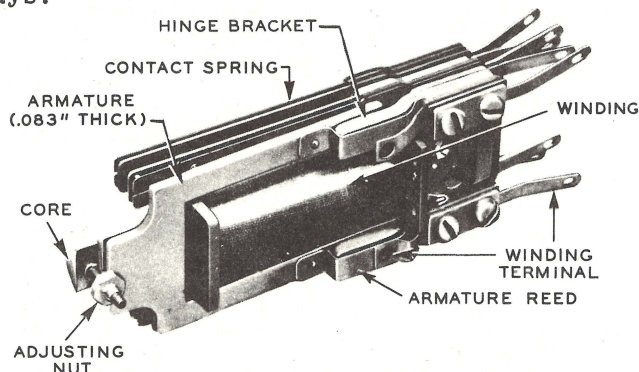

Fig. 13 - UA Type Relay with .083 Armature

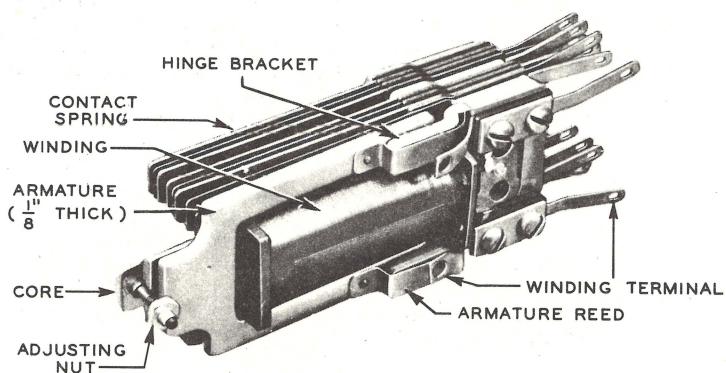

Fig. 14 - UA Relay with .125 Armature

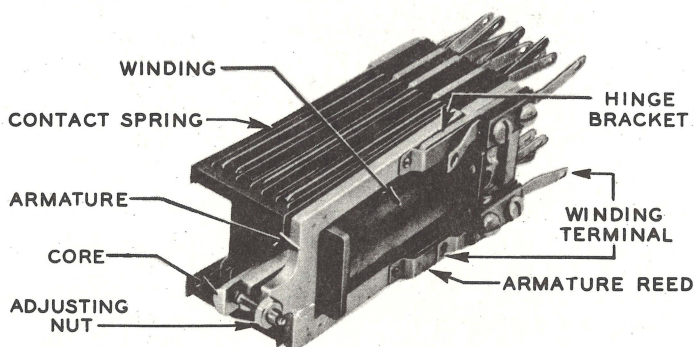
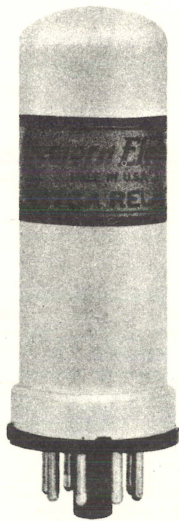

Fig. 15 - UB Type Relay

The UB type relay (Fig. 15) is a U type relay with a "card" arranged to replace the studs which transmit the armature pressure for moving the springs. The card consists of a piece of insulating material with slots that engage the tips of the moving springs. The card is intended to reduce changes in adjustment due to stud wear because the adjustment of each spring on the UB will only change by an amount determined by its own slot wearing whereas in the U type with one stud operating the following one, the wearing of all studs adds up to affect the last spring of a pileup. The card is also

intended to reduce the tendency of contacts to "lock" since the card may assist the springs in returning to normal. The UB is a general purpose relay and will mount interchangeably with U types of comparable design.

Section 5. The 275 and 276 Type Mercury Contact Relay



The 275 type relay (Fig. 16) consists of a 218A mercury switch surrounded by a winding coil and assembled in a metal vacuum tube shell equipped with an octal type vacuum tube base. The relay features high-speed non-chattering contacts capable of carrying relatively high currents and a representative use is in control circuits such as markers to quickly operate two or more multi-contact relays simultaneously.

The 218A mercury contact switch (Fig. 17) consists of an armature and two sets of contacts enclosed in a glass tube filled with hydrogen gas under 250 pounds pressure. The armature is a small piece of permalloy attached to a supporting spring and equipped with a contact arm. This arm normally rests against the back set of contacts which are made of non-magnetic material. The front contacts are attached to supports of magnetic material forming the upper pole pieces. The magnetic path through the switch includes these upper pole pieces plus the armature and the lower pole piece and when the coil is energized the armature is moved to the upper pole piece. The contact arm moving with the armature leaves the back contacts and comes to rest against the front contacts. Between the contact arm and the back contacts a drop of liquid mercury is gradually stretched until unable to bridge the gap any longer when it will fall away from the contacts and drop down to the bottom of the glass tube. When the contact arm has traveled far enough that the mercury on the arm and the front contacts joins, a new drop is formed which electrically bridges the gap until the contact arm comes to rest against the front contacts. Non-chattering break and make conditions in associated circuits are thus attained. A small amount of liquid for wetting the contacts is stored at the bottom of the glass tube and travels to the contacts through a small hollow tube through the armature by capillary action.

The 276 type relay differs from the 275 in being provided with a small permanent magnet attached to the front contact supports to increase its sensitivity and to permit it to operate and release within close limits of current flow.

No readjustment of the 275 or 276 relay can be made after manufacture and therefore no maintenance can be applied other than replacing a defective relay. These relays are preferably mounted in a vertical position but may be mounted as much as 30° from the vertical without affecting their characteristics. Due to the high pressure of hydrogen gas in the glass tube of the 218A switch, no attempt should be made to disassemble the 275 or 276 relay in the field.

Fig. 16  
275A and 276A Relay

Section 6. The 235 Type Thermal Relay

The 235 type relay (Fig. 18) is a thermal relay being operated by the heat resulting from a current flow instead of by the magnetic effect of that current. The relay is mounted on an E-type core with standard provisions for mounting on a 1 3/4 inch mounting plate with optional individual or complete strip covers. The relay is arranged to operate in time intervals from 3 to 25 seconds when 45 to 50 volts is applied to the heater. The rated time intervals apply when a cooling period of 2 minutes is allowed between operations. The relay consists of 1 or 2 pairs of bi-metallic springs secured in a pileup to the E-type core at one end and carrying contacts at the other end. A heater winding is placed around one spring of the pair and when current is applied to the heater, that spring is deflected and causes its contact to make with the stationary contact on the other spring. The use of similar bi-metallic springs for both contacts provides compensation for changes in room temperature since both springs are similarly affected, and the space between the contacts which determines the timing remains unchanged.

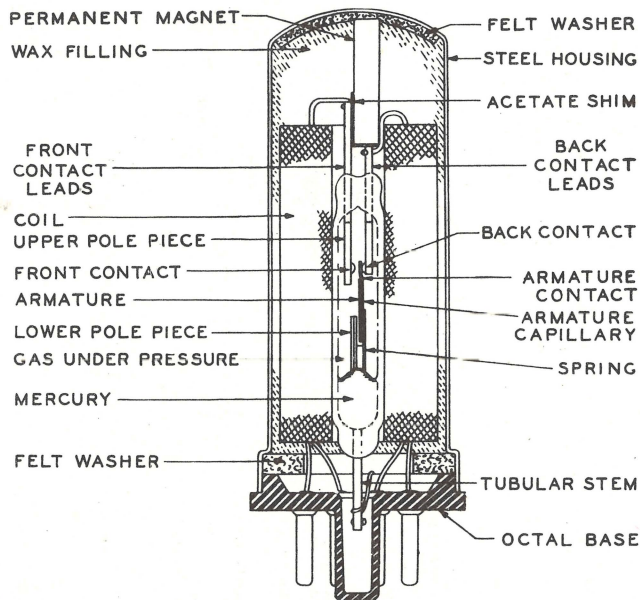

Fig. 17 - Cross Section of a 276 Type Relay

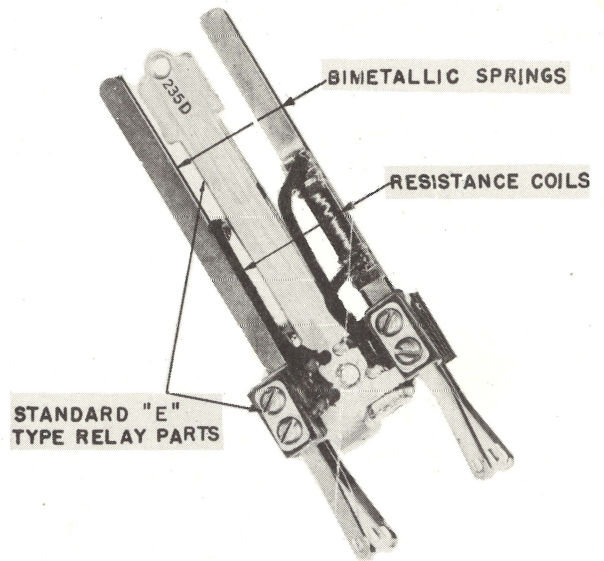

Fig. 18 - 235 Type Thermal Relay

Section 7. The Varistor

Varistors are so named because they have the property of varying their resistance according to the amount and direction of the voltage applied across the terminals. This property is used in two ways in telephone circuits: (1) to rectify alternating currents into direct currents; (2) to act as a bypass, around receiver and transmitter circuits, for the noise peak currents resulting from abnormal voltage surges. Varistors are of four general types; copper oxide, germanium, selenium, and silicon-carbide, each type having electrical properties particularly adapting it to certain uses.

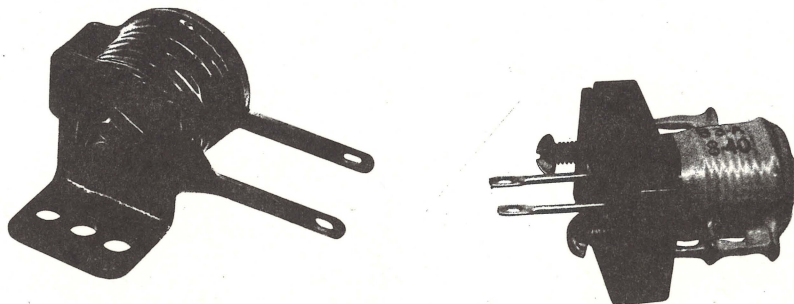

Fig. 19 - Copper Oxide Varistors

Copper oxide varistors (Fig. 19) consist of a washer or disc of sheet copper which has been oxidized so as to form on its surface a layer of red copper oxide. A film of conducting material is applied to the outer surface of this oxide layer and this film is known as the "outer contact", while the copper washer forms the "inner contact". A maximum of 3 volts AC may be applied across the two contacts which is a characteristic of the copper oxide film itself and variation of the size of the discs will not change the maximum voltage rating but will, rather, vary the current handling abilities. The 3A and 33A varistors of (Fig. 19) are examples of copper oxide varistors used as variable resistances and are intended for use across operators receivers to reduce clicks and other loud disturbances.

Germanium varistors (Fig. 20) consist of a pointed tungsten spring in contact with a processed germanium wafer. This is a rectifying type varistor unique in its ability to withstand high voltages across a single element. The 400A varistor of (Fig. 20) will stand 50 volts AC across its terminals.

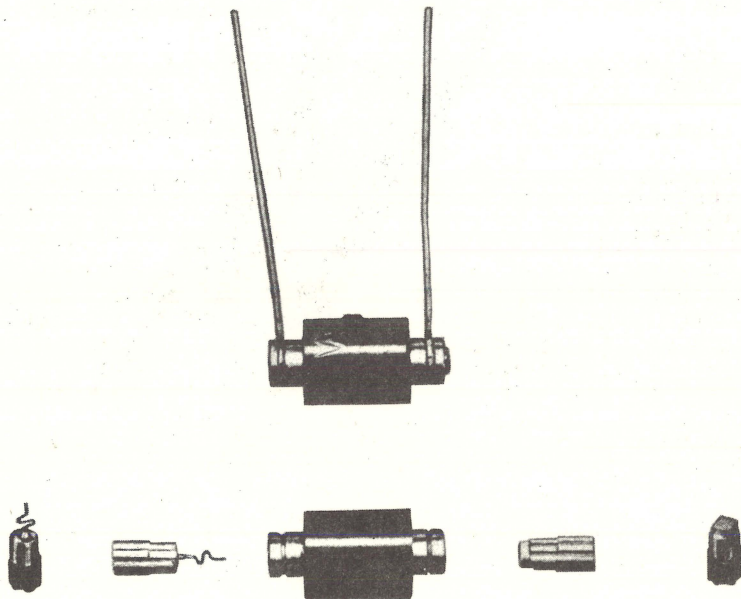

Fig. 20 - Germanium Varistor

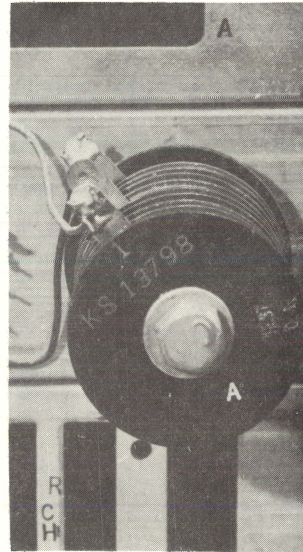

Fig. 21 - Selenium Varistor

Selenium varistors (Fig. 21) consist of a number of selenium cells assembled on an insulating sleeve. The cells are separated by metal separator-washers to allow free passage of air for cooling and are held under pressure by means of bolts or studs through the insulating sleeve. The individual selenium cells consist of an aluminum base plate coated with selenium on one side over which a metal alloy is sprayed. The aluminum base plate serves as one contact and the alloy as the other. Each of these cells is a rectifier and by suitable combination of the cells it is possible to form a rectifier having the desired voltage and current ratings. The selenium type varistor will stand 15 volts AC across each cell and has characteristics particularly adapting it for use where high temperatures, high voltages, or small size and light weight are deciding factors. A sample of the selenium varistor is the KS-13798 which is used as a source of positive, half-wave, rectified, 60 volt pulses for the subscriber message register.

The silicon-carbide varistors consist of a pile-up of silicon carbide discs alternated between metallic electrodes. These varistors are similar to the others in decreasing their resistance with an increase of voltage across the terminals but are unlike the others in that the resistance is independent of the direction of the applied voltage. Therefore they cannot be used as rectifiers but find their application as voltage limiting devices when connected across poorly regulated voltage sources feeding variable loads. An example of the use of the 300A varistor of (Fig. 22) is in the lamp circuit of some switchboards. This lamp circuit voltage, when sufficient to light many lamps at once, would rise rather high when only a few lamps were lighted if the 300A varistor did not resist the rise in voltage by lowering its own internal resistance.

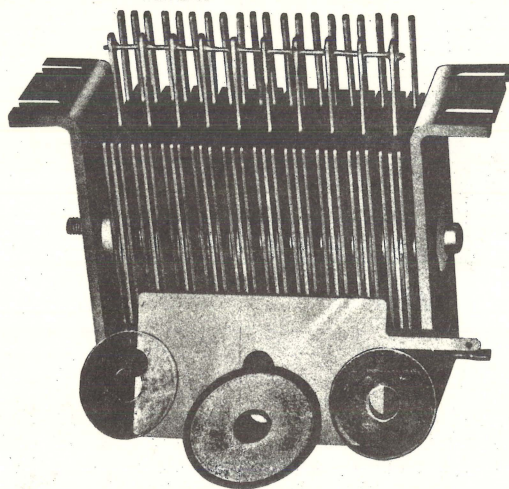

Fig. 22 - Silicon-Carbide Varistor

Section 8. Vacuum Tubes

The majority of electron tubes in Crossbar No. 5 circuits are of two types; hot-cathode vacuum tubes, and cold-cathode gas filled tubes. These two types operate on two different principles, the former requiring a heated source of electrical particles (electrons) operating in a nearly perfect vacuum, while the second makes use of the electrical particles (ions) present in a gas which is confined around two or more electrically charged elements. The following paragraphs will briefly describe the action of these two types of tubes and some of their applications.

The hot cathode vacuum tube depends for its action upon the fact that when certain metals or metallic compounds are heated to a high temperature there is a tendency for electrical particles (electrons) to boil out of the metal. These electrons surround the heated metal (cathode) in an electrically charged cloud similar to the cloud of steam surrounding boiling water. Certain metals are more efficient than others in their ability to release this electron cloud and certain special coatings on the heated metal also tend to increase their efficiency. The technical name given to the electron cloud around a cathode is the "space charge". If another element, not heated, is brought up close to the heated cathode, and if this element is given a positive voltage with respect to the cathode, the electrons will tend to flow from the cloud to the positively charged element. The positive element is known as the "anode" or "plate". For the electrons to successfully pass from the cathode to the anode, all air or other gases between the cathode and anode must be removed as much as possible and consequently hot cathode tubes are of the high vacuum type. Under these conditions of a heated cathode and positively charged anode confined in a vacuum, electrons will pass from the heated cathode to the positive plate resulting in the flow of an electric current from the plate to the cathode. The current flow is opposite in direction to the electron flow according to the present day arbitrary standards and will always be from the positive plate to the cathode as long as all emission is done by the cathode alone.

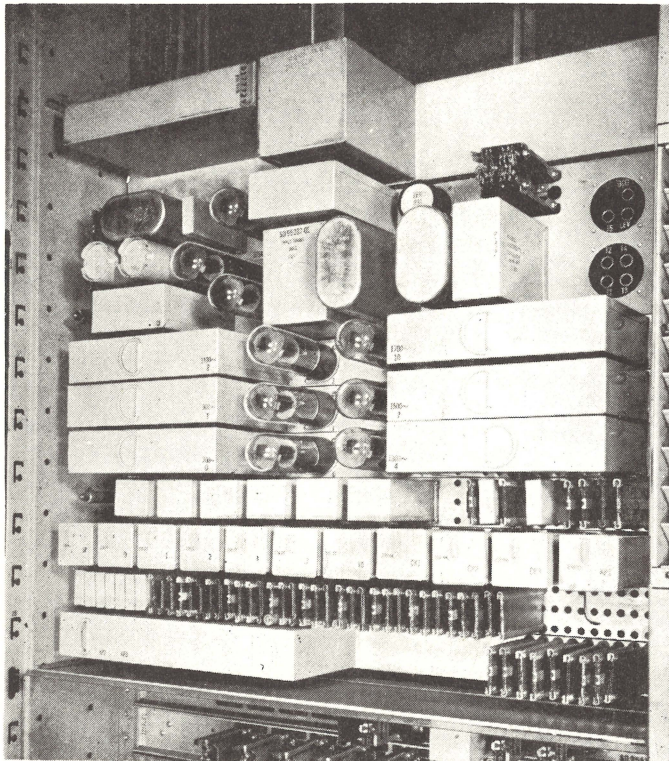

Fig. 23 - Multi-Frequency Receiver

self sustained action is known as oscillation. Representative uses of the grid controlled hot cathode vacuum tube are found in the multi-frequency current supply where these tubes are used as oscillators and in the multi-frequency receiver (Fig. 23) where they are used as rectifiers and amplifiers.

The cold cathode vacuum tube depends for its action upon the fact that gases under certain conditions can be made to break down into electrical particles both positive (ions)

When a third element is introduced between the hot cathode and the plate, and this element consists of a grid or mesh of fine wires, electrons can pass through the spaces of the grid to the plate. This grid, when made very negative with respect to the cathode, can halt the electron flow to the plate and if made positive will increase the flow. The grid therefore acts like an electron gate to control the current flow from plate to cathode and tubes with 3 or more elements are so designed that a minimum change of grid voltage will have a far greater effect upon the plate current than would the same change of plate voltage. Thus, hot cathode vacuum tubes with two or more elements can be used as rectifiers of AC into DC, and those with three elements or more can be used as amplifiers, or, as will be described, as oscillators.

The use of an amplifier tube as an oscillator is based upon the "feed back" of some of the amplified output from that tube into its own input circuit. This "feed back" when increased beyond the amount necessary to replace the normal circuit losses will start actions within the tube which finally become self-sustaining through repeated cycles of amplification followed by "feed back". This

and negative (electrons). When a gas is confined at atmospheric pressure or slightly below, and there is included within the confined space two or more elements capable of being charged electrically, the gas between the elements will break down if the voltage between the elements is raised past a certain critical value and an electrical current between the elements, will result. The pressure of the confined gas and the size, shape, and distance between the elements will determine that critical voltage. Certain gases break down more readily than others and each gas does so at a particular voltage. The cold cathode tubes used in Crossbar No. 5 systems are filled with a mixture of rare gases, consisting mostly of neon or argon depending upon the tube type. The pressure under which these gases are confined is slightly less than the 15 pound pressure of the atmosphere.

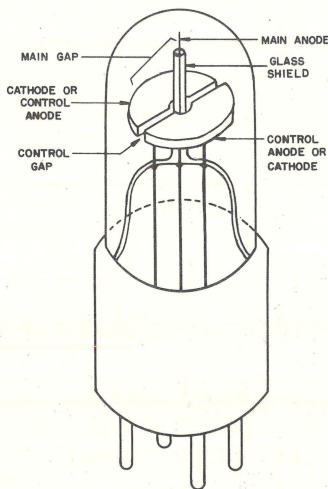

Fig. 24  
Cold Cathode Tube

An example of the cold cathode tube used in the telephone system is the 313 type of (Fig. 24). This is seen to be a 3 element tube containing two semicircular elements and one nickel wire element. The small nickel wire projects above a glass sleeve and is called the main anode. The semicircular elements are coated with activated barium and either of the two may be used as a cathode while the other serves as a control anode. The distance from the main anode to either semicircular element is called the main gap while the space between the two semicircular electrodes is called the control gap. The voltage necessary to break down the control gap of most 3 element cold cathode tubes is about 70 volts and the voltage necessary to sustain the break-down condition is about 60 volts; the main gap break-down voltage is generally above 150 volts and the main gap sustaining voltage is about 75 volts for most types.

Operation of a 3 element cold cathode tube is performed in two stages; (first) the control gap must break down thus allowing (second) the main gap to conduct. In this way a 3 element cold cathode tube may be used as a sensitive and fast-acting relay. The current required to ionize the control gap is less than 5 micro-amperes for most types and this value corresponds to the operating current of a relay in similar use. The time between voltage application to the control gap and conducting through the main gap is less than 1 milli-second and the "deionization" time is less than 10 milli-seconds. These correspond respectively to the operate and release times of a relay similarly used. A representative use of the 3 element cold cathode tube is found in the alarm timing circuits of Connectors used in the Crossbar No. 5 System. Other uses of cold cathode tubes include voltage regulators where two element tubes of the VR-150 type and the NE-2 type serve.

#### Section 9. Registers

Registers are electrically operated counters used to record the number of operations of the circuits they are associated with. Two general types of registers are used in the Crossbar No. 5 System and these are the No. 5-AJ subscriber message register and the No. 14-A traffic and plant register.

The No. 5-AJ message register (Fig. 25) also called a line register, is used to count the number of successfully completed calls made from a single or two party message rate line. This register is the same as was used in previous systems with the exception that a copper sleeve has been added between the register winding and the core. This sleeve, through slowing down the register release action, tends to eliminate the chatter of the register armature that would result from the use of a pulsating operate current. The Crossbar No. 5 System uses the sleeve wire of each message rate line for registration as well as for the usual connection-holding and busy test purposes. Registration uses an operating current of 60 pulses per second to separate it from the direct current performing the other operations.

The No. 14A (Fig. 26), when used as a traffic register, records peg counts, overflows, group busies, and other traffic load measurements for various frames and equipment units. These load indications are useful to traffic operating and traffic engineering people. When used as a plant register the 14A records trouble registrations, test calls and similar indications useful to the plant operating people. This register is light in construction and is capable of 20 operations per second. The number wheels and driving mechanism are enclosed in a removable black finished cover provided with a vinylite window and are in a separate unit from the magnet. This unit can be replaced if necessary without replacing the entire register.

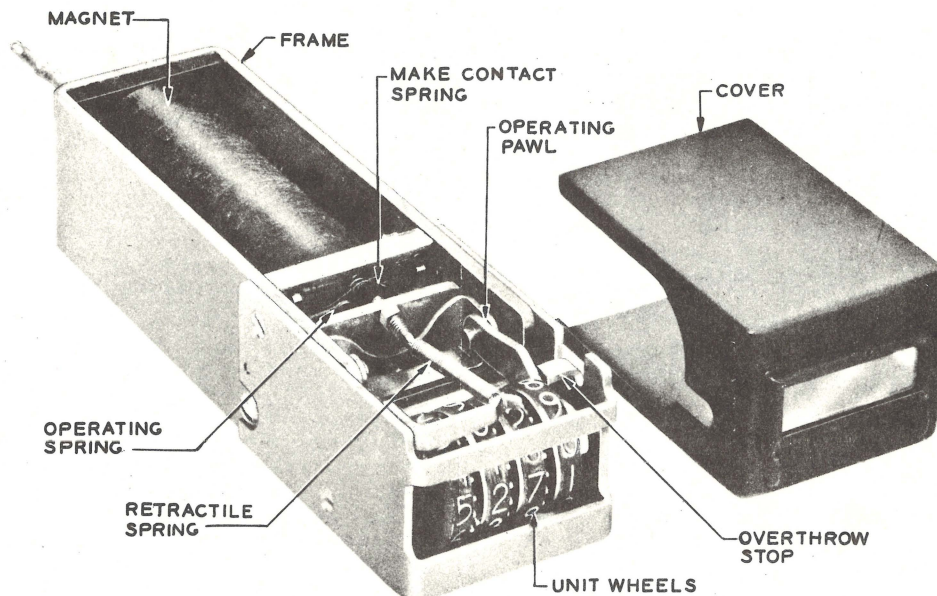

Fig. 25 - 5-Type Message Register

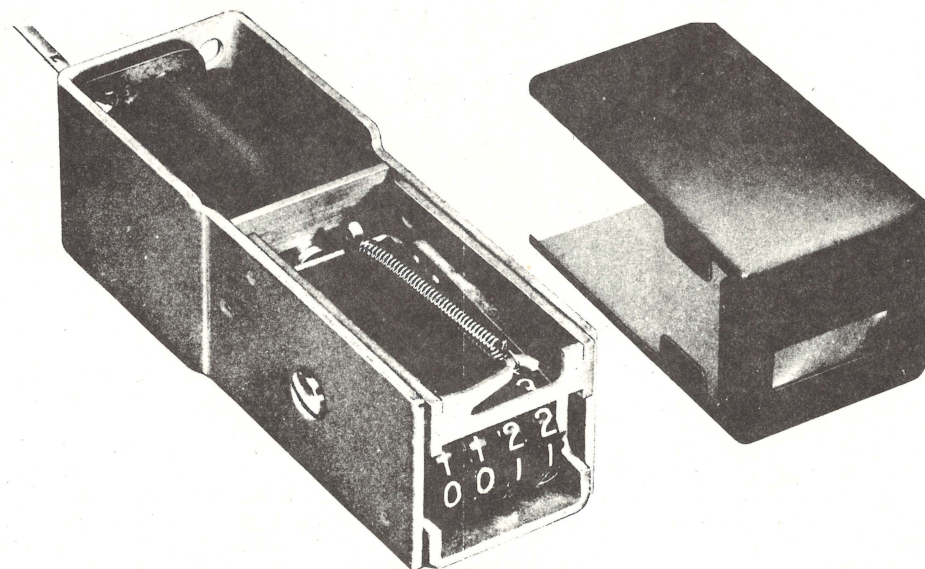

Fig. 26 - 14A Type Traffic and Plant Registers

#### Section 10. Filters

Filters are intended for use in multi-frequency incoming registers where they allow the passage of frequencies necessary to circuit operation and deny passage to all other disturbing frequencies. They are of two general types, the 128 and the 130 (Fig. 27). They consist of condensers and retard coils assembled in a metal case.

The 128-D filter (Fig. 27) will pass frequencies from 600 to 1900 cycles per second and is designed for insertion in a 600 ohm line. The 128-E filter (Fig. 27) passes frequencies above 600 cycles per second and is designed for insertion in a 635 ohm line.

The 130-C, D, E, F, G, and H filters of (Fig. 27) pass frequencies of 700, 900, 1100, 1300, 1500, and 1700 + or - 45 cycles per second respectively when inserted between a 600 ohm line and the grid circuit of a vacuum tube of approximately 120,000 ohms.

Section 11. Networks and Contact Protection

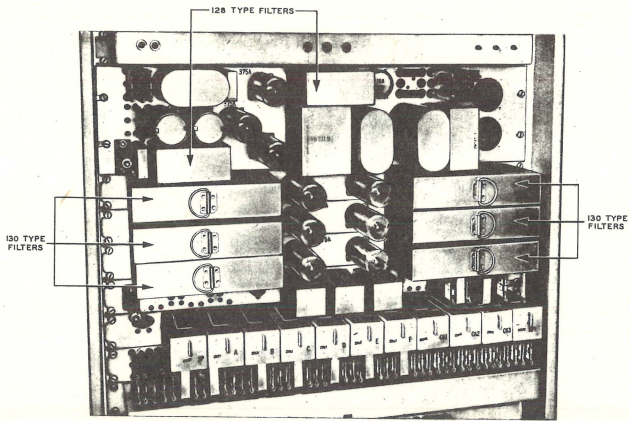

Fig. 27 - Type 128 and 130 Filters

bracket made as part of the network slips under the head of a relay mounting screw which then holds both the network and the relay to be connected to.

The 181 type networks are used when heavy duty components are required which take more mounting space than the 184 type. The 181 type networks are provided in a wide range of capacitance and resistance to accommodate the most severe conditions and are mounted with other equipment on standard mounting plates.

Protection in addition to that provided by the 181 and 184 type networks is given to contacts operating on relays using small contact separation gaps in the order of .003 of an inch. This additional protection consists of a 200CL coil mounting on or immediately behind a relay and connected directly to the relay contact so as to carry the same current as the contact. Bridged around the 200CL coil is an additional 181 type network which acts to absorb the kickback energy of the coil when the relay contacts open or close the circuit. The coil meanwhile serves to discourage the current surges resulting from an initial spark and which tend to prolong that spark across the contact gap.

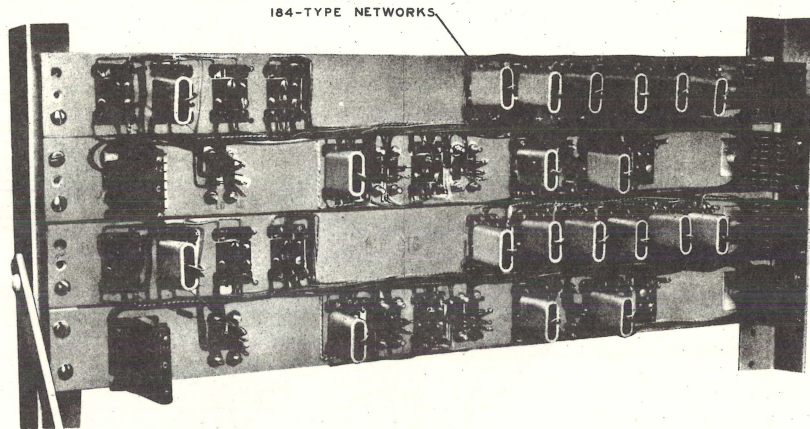

Fig. 28 - Method of Mounting 184-Type Networks

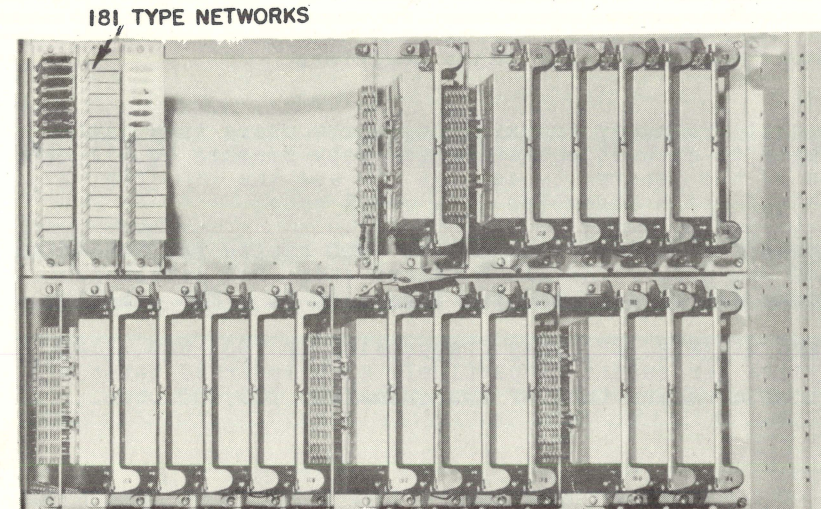

Fig. 29 - Method of Mounting 181-Type Networks

Networks for contact protection are of two general types, the 184 type (Fig.28) and the 181 type (Fig.29). The protection they provide is used to minimize the sparking which results in the locking together and the wasting away of contacts. The networks consist of a resistor and condenser in series arranged for connection across the winding of the relay which is being operated by the contacts to be protected. The network so connected affords a harmless discharge path for the violent kickback voltage resulting from the energizing or de-energizing of that relay.

The 184 type network is preferred for general contact protection service because it is small, requires no additional mounting space, and is slightly less expensive than other types. The mounting of the 184 type network is done on the wiring side of the equipment. The spade ended

Protection for mercury contact relays differs from conventional form mainly in the use of lower values of resistance and paired leads from relay to protection network. These differences arise from the relatively high speed of contact make and break giving rise to extremely rapid and heavy current surges.

CHAPTER IV

FRAMES

Section 1. General

The framework for the No. 5 Crossbar equipment is 11 feet 6 inches high, 10-1/2 inches deep, and is available in various widths from 20-1/2 inches to 45-1/4 inches. The arrangement of these frames on the floor places these frames in line with each other with the equipment sides of all frames in a row facing in the same direction. Adjacent rows have their equipment sides facing each other with a 3 foot aisle between them. The distance between the wiring sides of adjacent rows is 23 inches.

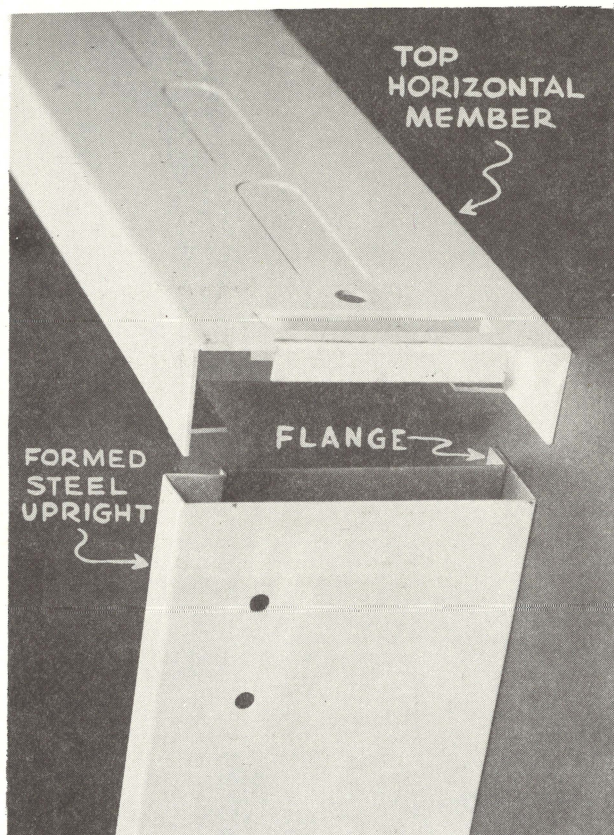

Fig. 30  
Details of Upright and Top Horizontal Member in No. 5 Crossbar Framework

Framework for the various frames uses 1/16 inch sheet steel uprights (Fig.30) formed in a hollow rectangular section and flanged in the rear to hold the apparatus mounting plates. The mounting plates may be mounted on either the front or rear of the flange. The hollow construction provides reduction in weight of more than one-half when compared with the bulb angle construction of Crossbar No. 1. Simultaneously these uprights are 3 times the strength of bulb angle uprights in the horizontal direction from front to back and are 1/2 as strong in the horizontal direction from left to right. The increased strength is in the direction to further resist "bowing" of the frame while the decreased strength is in the direction which is braced by equipped mounting plates. The flanges of the uprights are perforated with untapped 1/4 inch mounting holes on 1 inch vertical centers from top to bottom for the mounting plates. The uprights are also provided with mounting holes on 2 inch vertical centers for the horizontal sliding baffles between the uprights (Fig. 31) and with F slots at 2 inch intervals for hinging the front covers. Four screws are provided in the bottom of each frame for plumbing and leveling.

The base of the frame (Fig. 32) is also of formed sheet steel and mounts appliance outlets and, when required, fuse alarm lamps. The base houses a 110 volt AC appliance distributing box and its associated loom wire. When required the base will also enclose the condensers

and choke coil of a talking battery filter. The fuse panel when required, is mounted on the upright flanges immediately above the base and below the first mounting plate position.

Cable brackets which also serve as the support for the rear covers (Fig. 33) are mounted at intervals down the back of each upright. These rear covers, 3 of which enclose the back of a bay, are held in place with two turn latches located near the top of each cover.

The front covers (Fig. 34) are provided when protection from dust and mechanical interference or damage is required. These covers may be either aluminum or transparent plastic and of heights varying from 8 to 14 inches. The transparent covers permit observation of relay operation, alarms, switch positions and etc., without removal of the cover. Provision is made in the uprights for horizontally hinging the front covers which open downwards and hang over any lower covers in the closed position.

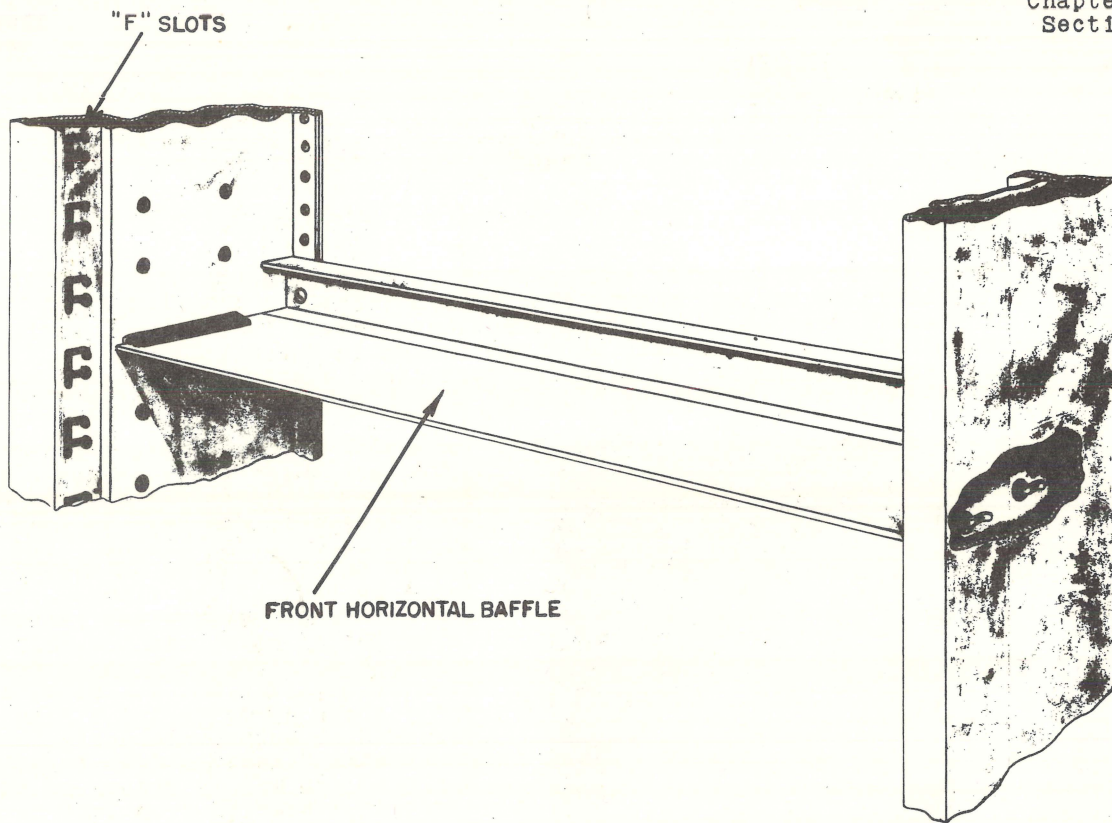

Fig. 31 - Details of Front Horizontal Baffle

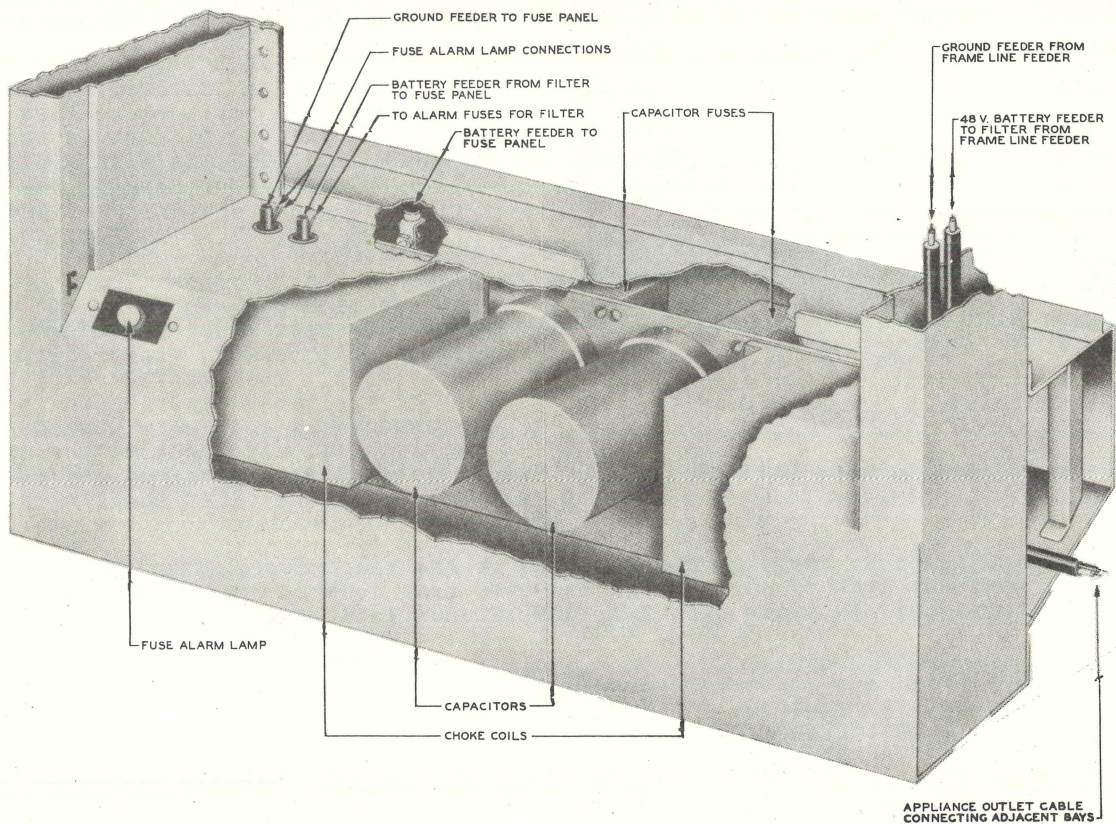

Fig. 32 - Base of Frame Showing Talking Battery Filter and Power Feeders

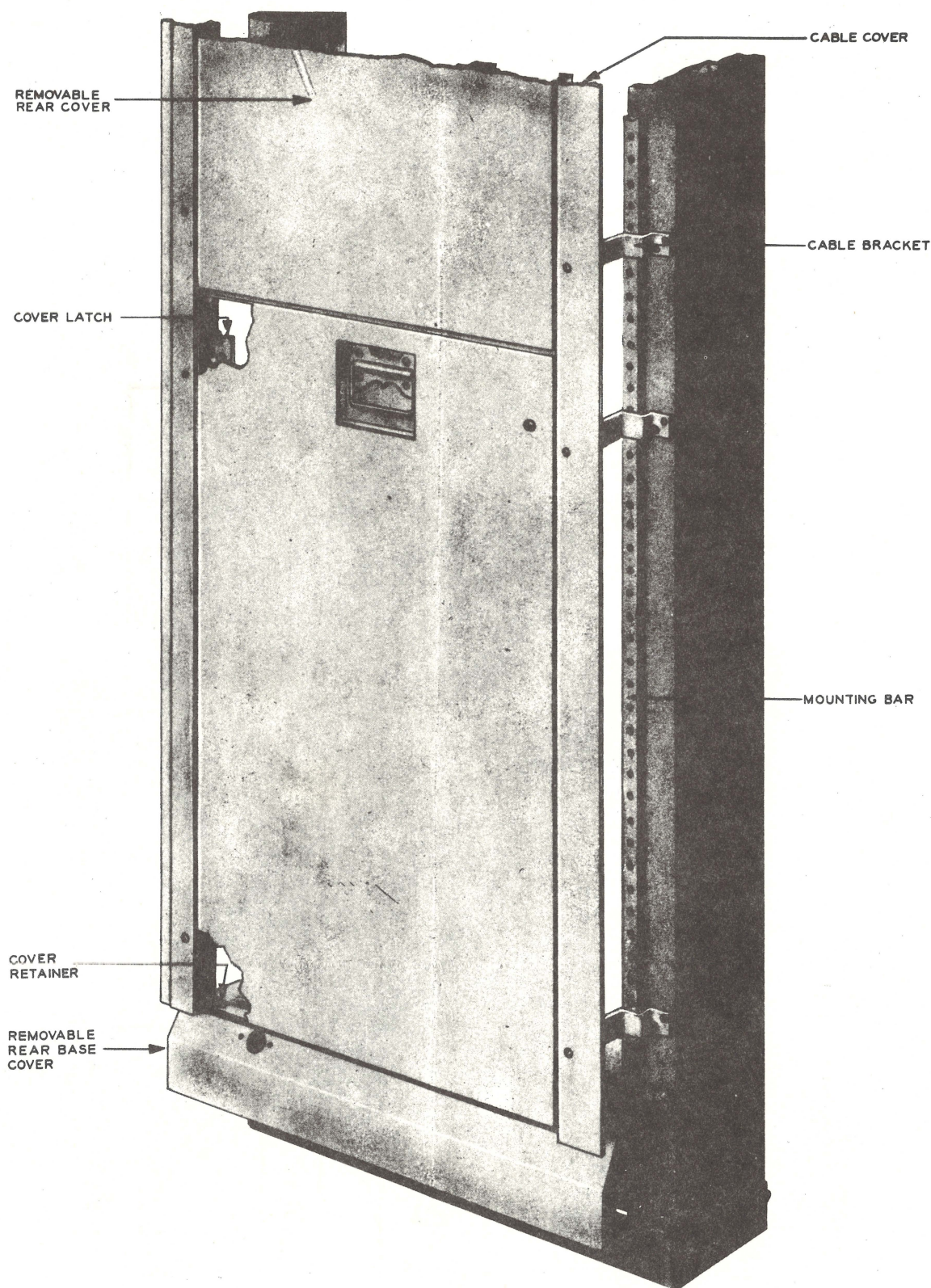

Fig. 33 - Details of Rear Covers

Front horizontal baffles (Fig. 31) are provided to discourage updrafts in the apparatus space of frames enclosed with front panels, and thereby retard the spread of dust and, possibly, fire. These horizontal baffles mounted even with the top of the highest front door and with the bottom of the lowest door complete an enclosure of the equipment consisting of front doors, horizontal baffles and apparatus mounting plates. Horizontal

baffles are also mounted in various other positions between units and are arranged to slide into spring guides which clip to the inner face of the uprights at 2 inch intervals.

Rear horizontal baffles supported on brackets are also provided to prevent updrafts and retard the spread of dust and, possibly, fire. Rear vertical baffles are provided between adjacent frames in the wiring space to also act as separators for fire control.

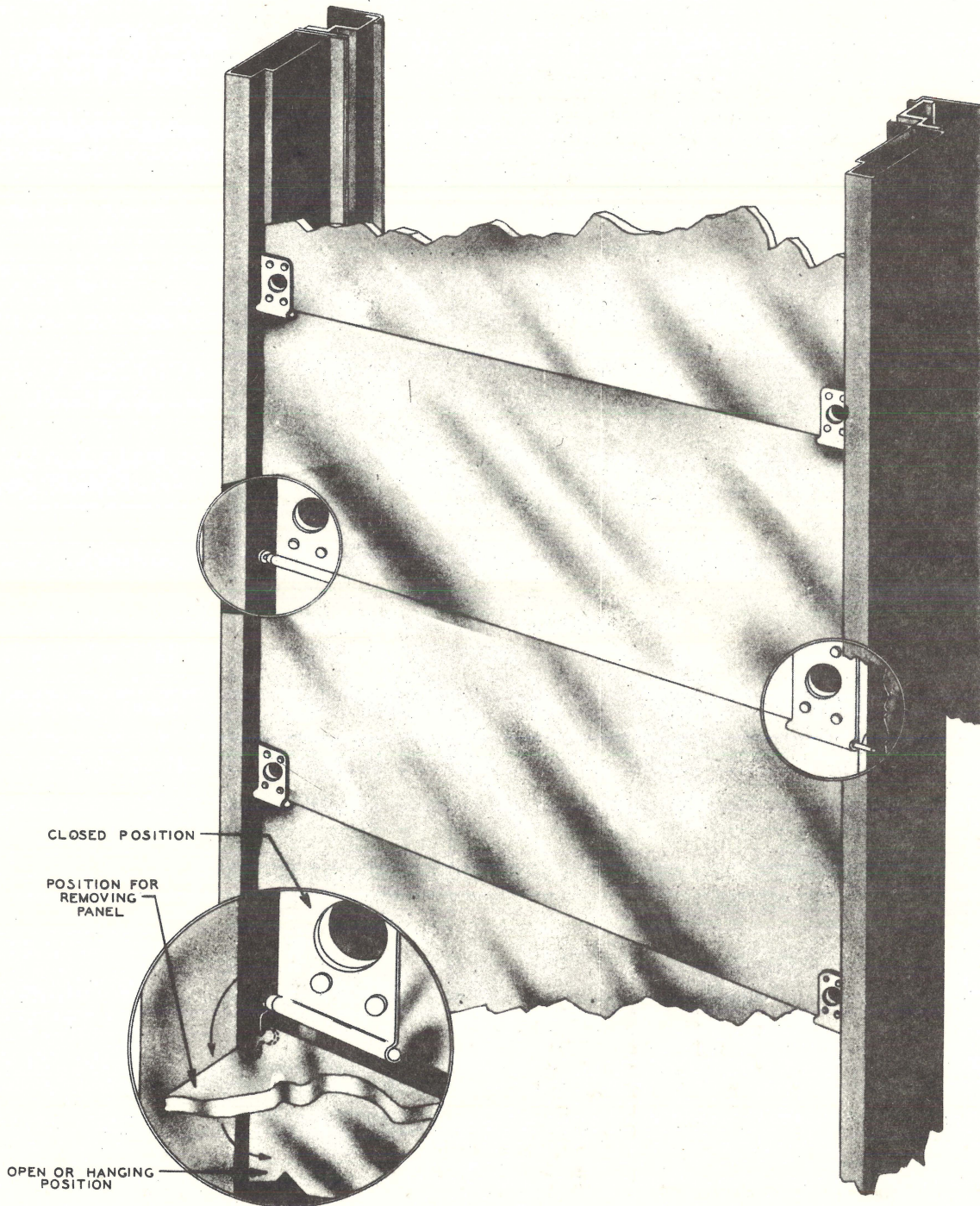

Fig. 34 - Details of Front Covers

End guards (Fig. 35) are provided to enclose the wiring space of the end frames in a row and consist of flat sheet steel panels fastened to the uprights so as to interlock with the fixed portion of the rear covers. The aisle pilot lamps and associated alarm relays are mounted on these end guards. Provision is also made for mounting a cabinet for the 100 ampere fuse carrying 48 volt signal battery to the frames of a row.

Top horizontal members (Fig. 30) are hollow formed T sections located with a space between them permitting cables or fastening devices to pass vertically through the space into the hollow uprights. Armored lamp cord for the 110 volt AC service, as well as the 48 volt signal battery and ground leads are run inside the hollow uprights (Fig. 32).

### Section 2. Line Link (LL) Frames

The basic Line Link frame consists of two bays each mounting 10 three wire 200 point switches (Fig. 36). Each switch has 20 verticals thus providing 200 verticals per bay. The verticals of the right-hand bay in the basic unit terminate 190 subscriber lines and 10 No. Test circuits while the verticals of the left-hand bay terminate 100 subscriber lines and 100 junctors. Thus the right-hand bay is called a line switch bay and the left-hand bay is the combined line and junctor switch bay. The 290 line capacity of the basic unit may be increased in steps of 100 lines to a maximum of 590 lines by the addition of Supplementary Line Link bays of either 100 or 200 line size. The junctor capacity of any size line link frame remains 100.

Mounted on each line link basic unit and on each supplementary line link bay is one fuse panel near the base and various relays near the top. These relays include line relays furnished once per line, line group relays furnished once per 5 lines, vertical group relays furnished once per 50 lines, and on the basic unit only are 10 multi-contact relays, one for each horizontal group of lines.

The line link frame serves to link lines with junctors and is used for both originating and terminating traffic. Each line on a frame has a possible link path to every one of the junctors on that frame for originating traffic and each junctor has a possible link path to every line on that frame for terminating traffic. A link path consists of a horizontal circuit on a junctor switch connected through local cable on the wiring side of the frame to a horizontal circuit on a line switch. The 10 horizontal circuits of the 10 line switches in the combined line and junctor switch bay (100 horizontal circuits total) are multiplied straight across to the 10 horizontal circuits of the 10 line switch bay switches and again to the horizontal circuits of all equipped supplementary line switch bays. Thus all lines in a horizontal row of line switches have access to the same 10 horizontal circuits. Linking together of a line and a junctor is accomplished by the marker operating the select and hold magnets in the associated line and junctor switches.

The one line link frame will serve subscribers having 30 different classes of service including Automatic Message Accounting (AMA), Message Rate (MR), and Coin (C).

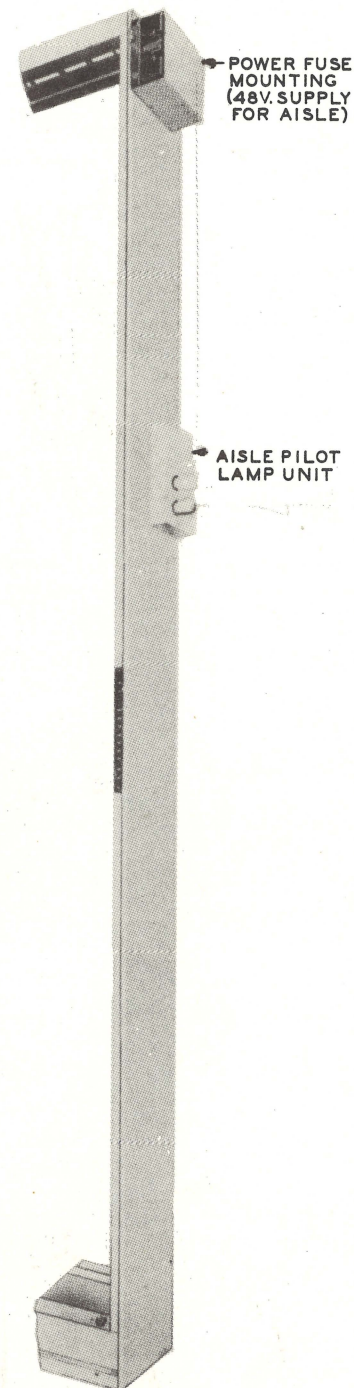

Fig. 35 - Details of End Guards

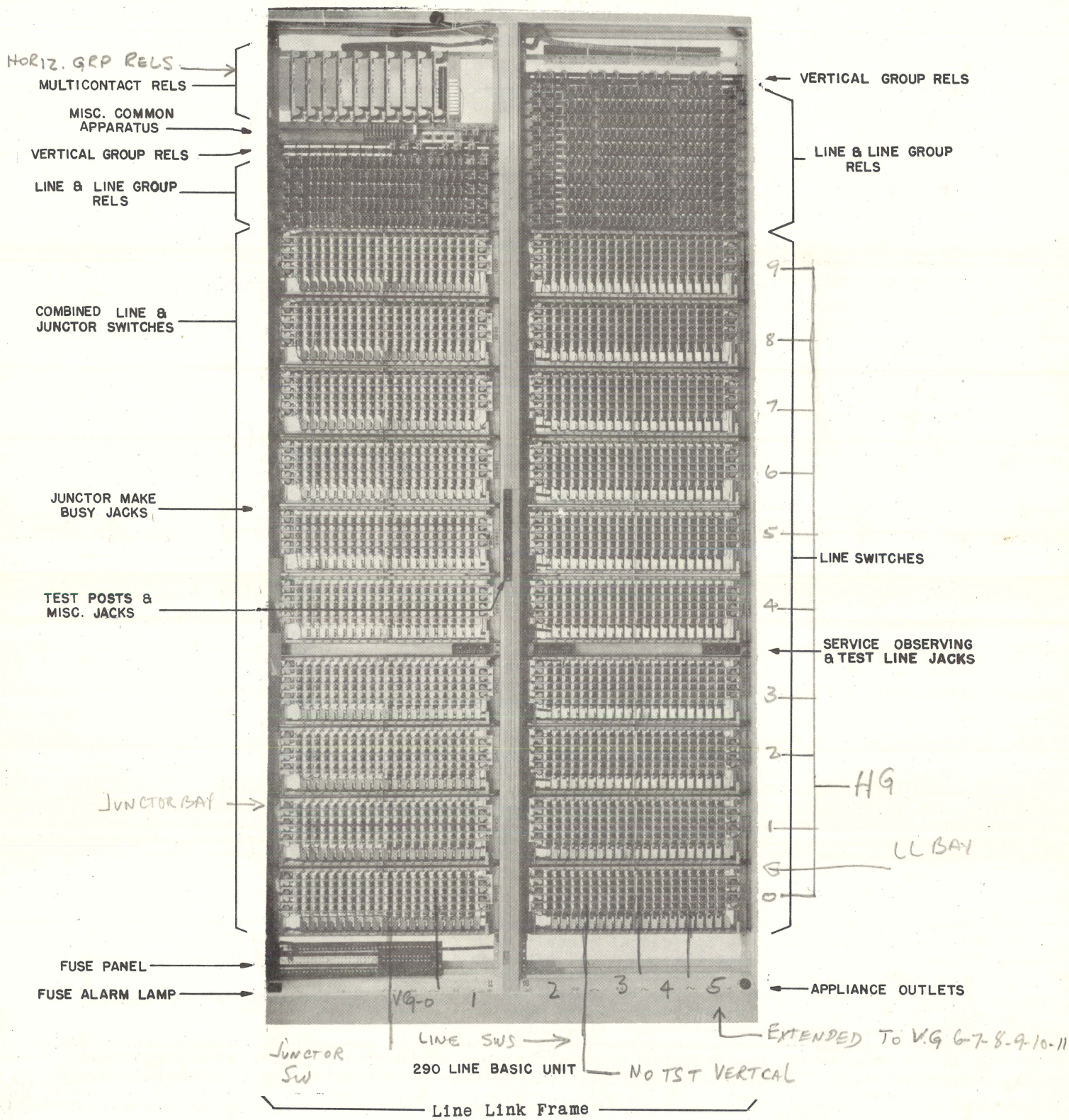

Fig. 36

FROM 6 TO 9. ONLY ONE APPEARANCE ON THE SW.

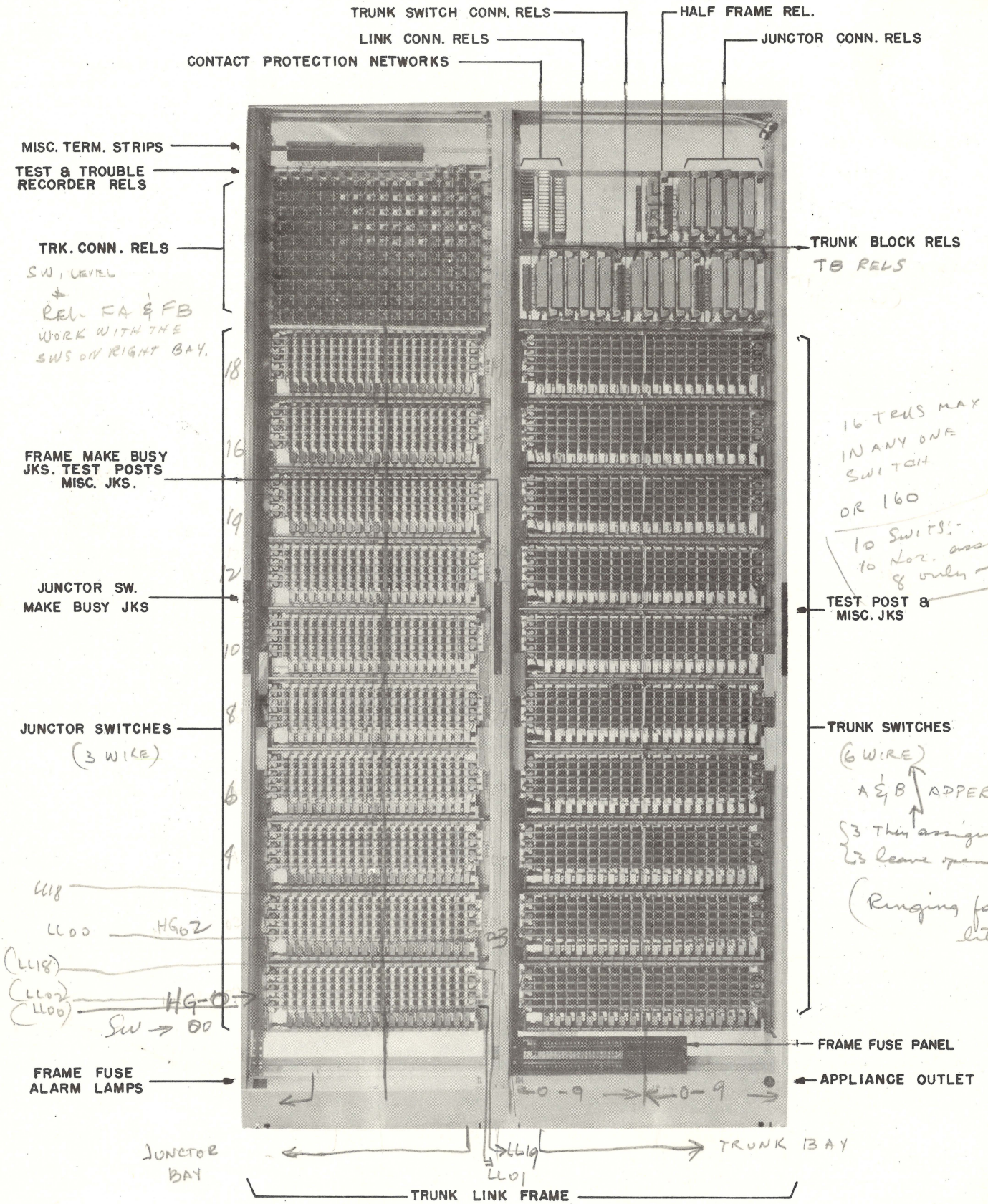

Fig. 37

Section 3. Trunk Link (TL) Frames

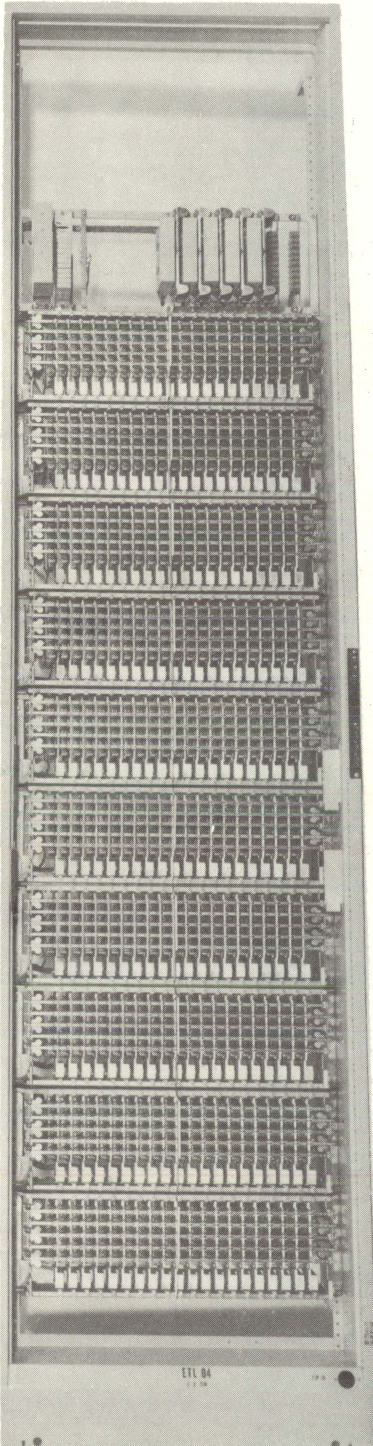

Fig. 38  
Extension Trunk Link Frame

job above 20 line link frames, a maximum of 40 may be accommodated through the addition of an extension trunk link frame to each trunk link frame. This effectively doubles the junctor capacity of a trunk link frame by adding the 10 junctor-switches of the extension frame. With the call handling ability of the trunk link frame remaining the same, doubling the number of junctors requires that two trunk link frames

The Trunk Link frame (Fig. 37) is a two bay framework arranged to accommodate ten 200 point three wire crossbar switches and 160 U type relays in the left or junctor switch bay, and ten 200 point six wire crossbar switches, 18 multi-contact relays and a fuse panel in the right or trunk switch bay. The horizontal circuits of the junctor switch bay will terminate 200 junctors and the horizontal circuits of the trunk switch bay will accommodate 160 trunk appearances which serve as terminations for intra-office trunks, incoming trunks, outgoing trunks, and originating registers. The 160 trunk appearances of any one trunk link frame may either terminate 80 intra-office and incoming trunks requiring ringing with the remaining 80 appearances terminating trunks of other types and originating registers, or 120 outgoing trunks with the remaining 40 appearances being used for incoming trunks. Not more than 60 of the 120 outgoing trunks may be of a type requiring senders.

The 160 U type relays in the junctor switch bay are trunk-connect relays furnished one per trunk appearance on the trunk switches. The 18 multi-contact relays in the trunk switch bay are used as 36 individual half relays by the marker during the instant of establishing a channel through the trunk link frame.

The trunk link frame serves to link junctors with trunks or registers. Each junctor on a frame has a possible link path to every one of the trunks or registers on that frame for originating traffic and each trunk has a possible link path to every junctor on that frame for terminating traffic. A link path consists of a vertical circuit on a junctor switch connected through local cable on the wiring side of the frame to a vertical circuit on a trunk switch. The horizontal circuits of each junctor switch are split in the center and the 10 junctors on the left horizontals of a switch all have access to the same 10 vertical circuits, or links while the junctors on the right half horizontals, all have access to another 10 link circuits. Linking together of a junctor and a trunk is accomplished by the marker operating the select and hold magnets in the associated junctor and trunk switches.

Section 4. Extension Trunk Link (ETL) Frames

The Extension Trunk Link frame (Fig. 38) is a single bay framework arranged to mount ten 200 point 3 wire crossbar switches, four U type relays and 5 multi-contact relays. Extension trunk link frames, when required, are furnished once per trunk link frame and each is numbered the same as its associated frame. The 200 vertical circuits on the switches of the extension trunk link frame serve as a multiple appearance of the 200 links terminating on the corresponding junctor-switch vertical-units of the trunk link frame. The horizontal circuits on the switches of the extension trunk link frame are split the same as those on the trunk link junctor-switches, and provide terminations for 200 more junctor circuits.

The junctor capacity of a trunk link frame will allow termination of 10 junctors from each of 20 line link frames. When it is desired to increase the size of a frames. When it is desired to increase the size of a

with associated extension frames be made to share the same 400 junctors. This is accomplished by multiplying the junctor-switch horizontals of pairs of trunk link frames and similarly multiplying the junctor-switch horizontals of the associated extension frames. The final result after adding extension trunk link frames is a unified arrangement of 40 line link frames and 20 trunk link frames using one marker group as compared to the previous maximum of 20 line link frames with 10 trunk links.

Section 5. Marker (M) Frames

The Marker (Figs. 39 to 42) is the largest of the common control circuits with the equipment of one marker occupying space as follows:

- A. ✓ Common Equipment Frame
- B. ✓ Translator and Route Relay Frame
- C. ✓ Trunk Frame Test Lead Connector Frame
- D. ✓ Class of Service Frame

There are 3 types of markers, (1) Combined, (2) Dial Tone, and (3) Completing. The combined marker performs all marker jobs; the dial tone and completing markers divide the jobs of the combined marker between them. The (A) marker frame constitutes the entire dial tone marker, and is one of 4 frames occupied by combined and completing markers. The (A) and (B) marker frames are furnished once per combined or completing marker and are placed next to each other on the equipment floor with the common equipment frame on the left. The (D) marker frame is furnished once per 4 combined or completing markers, and the (C) marker frame is usually furnished once per 6 combined or completing markers. All the markers serving in common a maximum of 20,000 lines are called a marker group, and each marker group consists either of all combined markers or a sub-group each of dial tone and completing markers.

The common equipment frame, (Fig. 39) or "A" marker frame, is a two bay framework containing most of the equipment needed in common by all markers on all jobs. This equipment prior to mounting on the common equipment frame has been assembled and wired in units of from 3 to 7 plates and these units are used in "building block" style to make up markers for particular jobs. Wiring of the units is of the "loose surface" type with no terminal strips, and wiring between units is carried in the local cable. Both bays of the common equipment frame are designated common equipment bays.

The translator and route relay frame, (Fig. 40) or "B" marker frame, is a two bay framework mounting equipment which varies more widely from job to job. This equipment is also furnished in "building block" units and the right-hand bay mounts the translator and route relay units with associated cross connection terminal strips while the left-hand bay mounts the common equipment closely associated with the translator and route relay functions. One hundred route relays, which are of the UB type, can be mounted in the translator and route relay frame and when more routes per

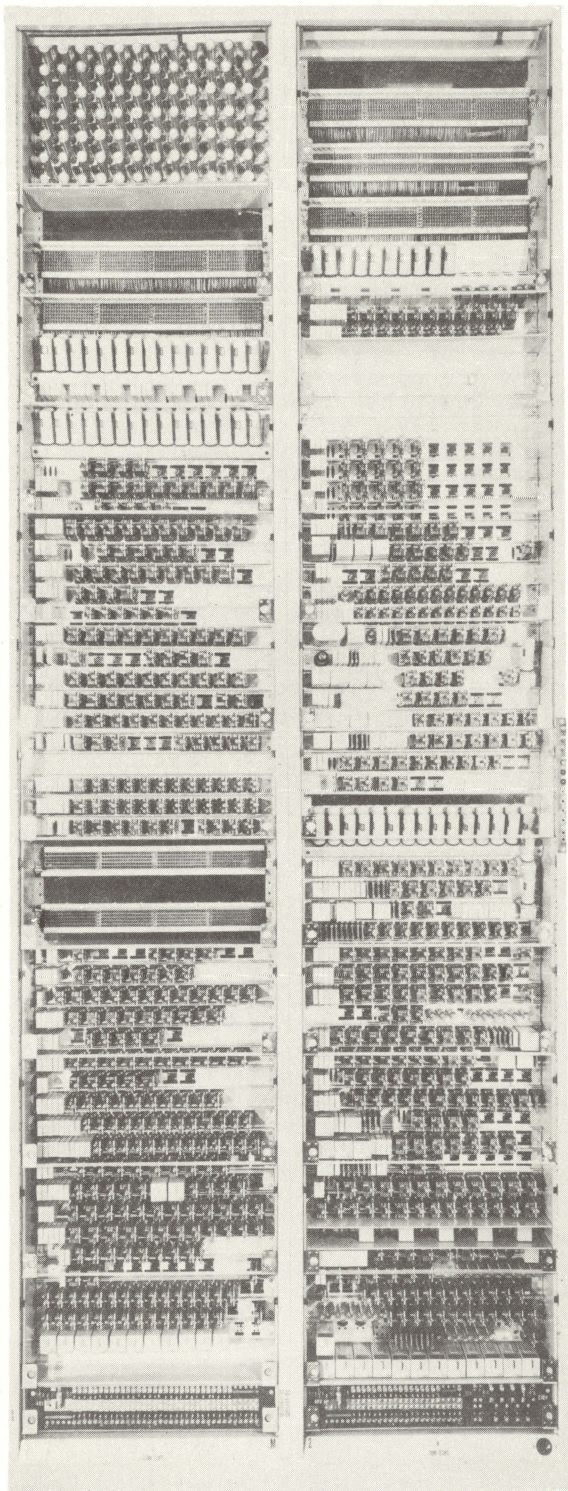

Fig. 39 - Common Equipment Frame  
Portion of No. 5 Crossbar Marker



Fig. 40 - Translator and Route Relay Frame Portion of No. 5 Crossbar Marker

marker are needed supplementary route relay bays may be furnished which will each mount 200 route relays and their associated cross connecting fields. The 200 route relays of a supplementary bay may, when required, be associated as 100 relays with each of two markers. One hundred ten translator relays may be mounted on the translator and route relay frame of which 10 may be used for A digit translation and the remaining 100 used for B digit translation. Ten of the 100 might also be used for toll-center switching translation.

The class of service frame (Fig. 41) consists of a single bay framework mounting the class of service relays, and their cross connecting fields, for 4 markers. The class of service relay units for two markers are mounted at the top of the bay and for the other two markers at the bottom of the bay. The class of service cross connection fields are mounted in the center of the bay between the top and bottom relay units and provide facilities for cross connecting between the class of service relays and the route relays.

The trunk frame test lead connector frame (Fig. 42) is a single bay framework mounting the cut-in relays through which a marker examines all trunk link frames for idle registers and idle trunks. These trunk link frame cut-in relays are provided once per marker per route per 10 trunk link frames. Each trunk link frame connector bay will serve 6 markers with 80 routes each through 10 trunk link frames. When more routes or more trunk link frames must be served an additional trunk frame test lead connector frame may be added.

#### Section 6. Register (OR and IR) Frames

Register frames (Fig. 43) are two bay frameworks mounting a maximum of 5 registers extending across both bays. Each Bay always accommodates a fuse panel at the bottom, a multi-contact relay unit at the top and two miscellaneous equipment mounting plates just below the latter. Register frames are of two classes, originating registers and incoming registers with each further classified according to the manner in which information is transmitted to the register, such as Dial Pulse Registers, Multi-frequency Registers, and etc. All registers are assembled out of ten loose wired units, each of from one to four mounting plates. Five of these units are universally required on all jobs and the remaining five furnish such features as may be required when the registers must accommodate more than four digits, make two party or coin tests, and etc. These latter five units each perform

certain operations and are furnished according to the need for those operations. Terminal strips mounted on both ends of each unit accommodate leads to other units in the same register and to the multi-contact relay units at the top of the frame.

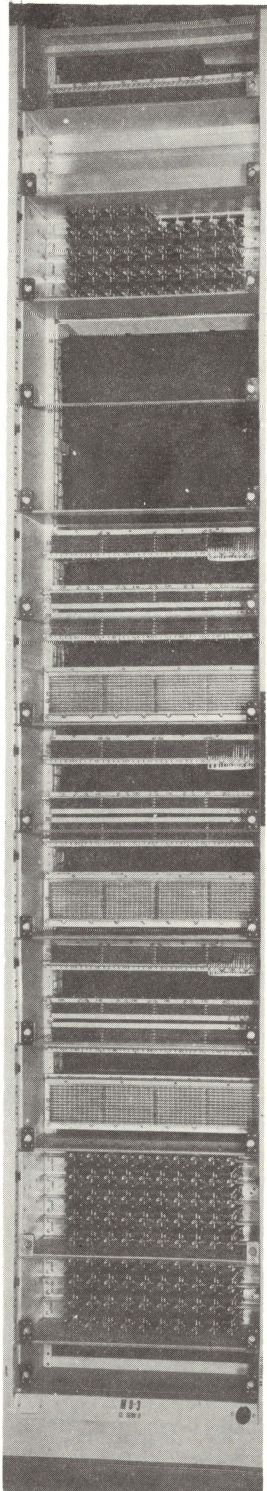

Fig. 41 - Class of Service Frame  
Portion of No. 5 Crossbar Marker

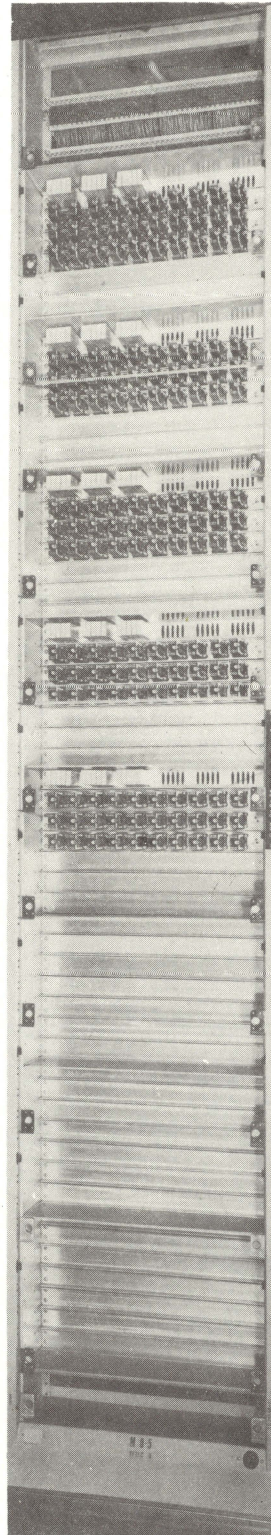

Fig. 42 - Trunk Frame Test Lead Connector  
Frame Portion of No. 5 Crossbar Marker

(LEFT-OFF (TAKE PULSES FROM THE SUBSCRIBERS SET.) (equipped for 11 digits)

No Lvs hest nly pts

The Dial Pulse Originating Register (Fig. 44) is used to transmit dial tone to a calling subscriber and to store his dialed information, digit by digit, as it is dialed. When dialing has been completed the dial pulse originating register transmits this called telephone number to the marker along with other information including the calling line's location in the line link frames and its class of service. Upon signal from the marker that a path to the called number has been supplied the dial pulse originating register will be released having meanwhile been continuously held since the transmitting of dial tone. Thus it may be seen that the dial pulse originating register, as a piece of common control equipment, is the direct opposite of the marker in these respects: it is the smallest of the common control circuits, the least expensive, it is furnished in much greater numbers, and is held the greatest length of time per call. Further, the register holding time will vary from call to call and from area to area with the number of digits to be dialed, in all cases being a matter of many seconds while the marker holding time will not vary appreciably, remaining always a fraction of a second. Dial pulse originating registers are wired to trunk appearances on trunk link frames for connection to paths from calling subscribers.

The Multi-Frequency Originating Register (Trial Basis, Media, Pa., 1949) differs from the dial pulse originating register in the manner of receiving its information from a calling subscriber. In all other respects the two registers are exactly alike. The multi-frequency originating register is for use by calling subscribers whose sub-sets are equipped with multi-frequency key sets instead of dials, the dial pulse counting and dial pulse register units of the register being replaced by corresponding multi-frequency pulse units.

The Dial Pulse Incoming Register is used to receive the called telephone number from a step-by-step, tandem, or manual office arranged to transmit dial pulses. This called number, plus the incoming trunk identifying information, is transmitted to a marker for selection of a talking path after the incoming register has completely stored all incoming digits in the dialed sequence. The dial pulse incoming register is built up of 12 surface wired units, 6 of which are required on all jobs and the remaining 6 furnishing the additional features required for more than 4 digits, for tandem and toll switching, and etc. Dial pulse incoming registers are wired to incoming register link frames for connection to incoming trunks.

The Multi-Frequency Incoming Register serves to receive the called telephone number from a Crossbar local, tandem or toll office, or Manual office switchboard equipped for MF pulsing.

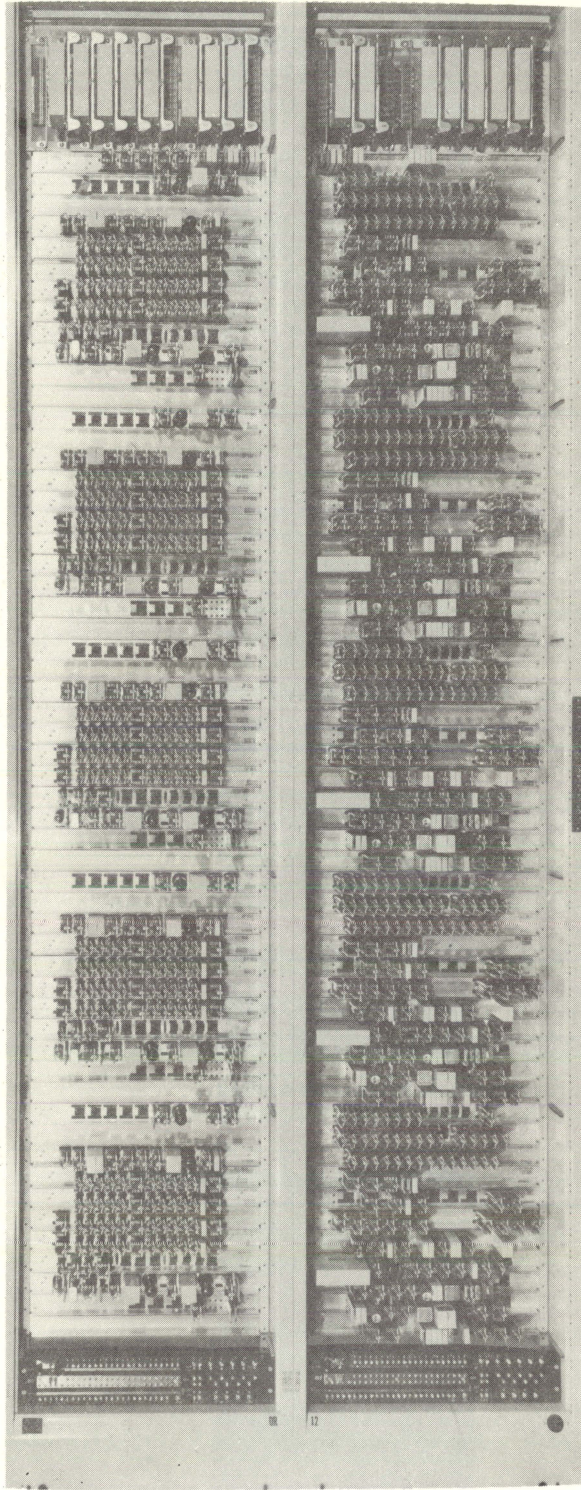

Fig. 43 - Originating Register Frame

The register is composed of 7 loose surface wired units, 5 of which are required on all jobs, and the remaining 2 furnishing additional features required to accommodate more than 4 digits, to complete tandem calls, and etc. Multi-frequency registers are wired to incoming register link frames for connection to incoming trunks and in the older type units to multi-frequency register units (Fig. 45) mounted (maximum 6 units) on the miscellaneous relay rack. Present type incoming registers include the multi-frequency register unit.

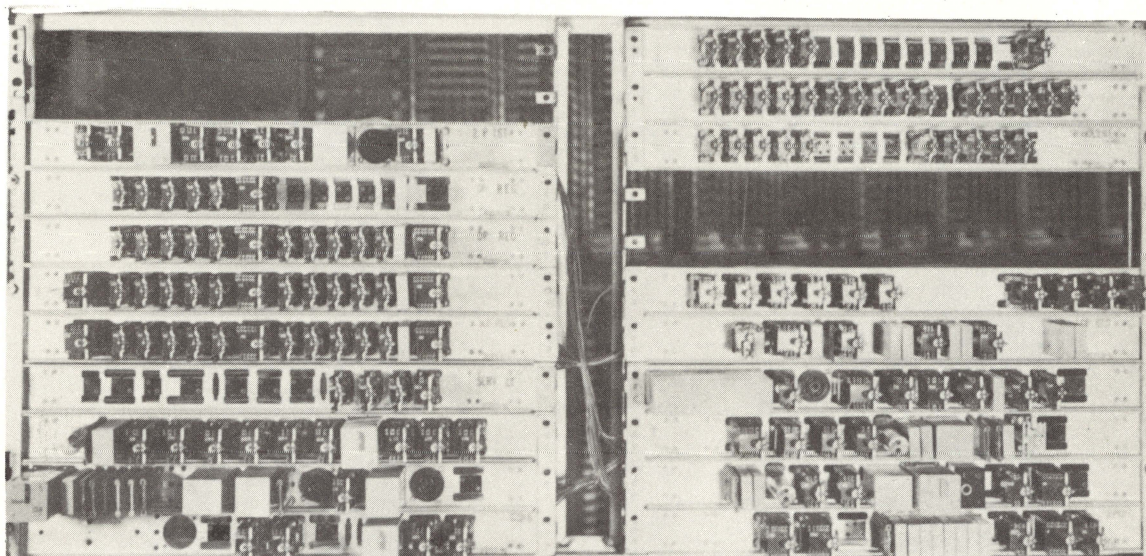

Fig. 44 - Dial Pulse Originating Register

The Revertive Pulse Incoming Register performs the same functions as other incoming registers, differing in being equipped with means to generate pulses which, when reverted back to a sender at the originating panel, crossbar, or tandem office, provide pulsed selections which identify the called telephone number. The revertive pulse incoming register is composed of 5 surface wired units, 4 of which are required on all jobs and the remaining 1 furnishing the additional features to accommodate more than 4 digits, complete toll and tandem calls, and etc. Revertive pulse incoming registers are wired to the incoming register link frame for connection to incoming trunks.

The Central B Incoming Register is a modification of the revertive pulse incoming register described above. The modification consists of permanently associating each register with a Central B Sender and Position Finder (Chapter IV, Sec.9) to allow straight forward operation over trunks incoming from manual A or other operators. The central B incoming register is composed of 5 surface wired units, 4 of which are required on all jobs and the remaining one furnishing optional additional features to accommodate more than 4 digits to complete toll and tandem calls, and etc. Central B incoming registers are wired to the incoming register link frame for connection to incoming trunks and to central B sender and position finders for connection to B operators.

Originating and incoming registers of all types are wired to the multi-contact relay units at the top of the register frames for connection to the register end of the associated register marker connectors. Two multi-contact relays per register are required for jobs accommodating a maximum of 8 digits and a third multi-contact relay is required for a maximum of 11 digits. This third relay is mounted on an Auxiliary Register Marker Connector (ARMC) frame for originating registers and on the incoming register frame for incoming registers.

#### Section 7. Pretranslator (PRT) Frames

The Pretranslator frame (Fig. 46) is a single bay framework mounting 2 pretranslator units and their associated 2 pretranslator connectors. The bay is also equipped with a fuse panel and a two plate common control unit at the bottom, and two terminal strip rows at the top. Each pretranslator unit consists of 11 relay mounting plates and a cross-connecting field occupying the space of 6 relay mounting plates. Each pretranslator connector circuit occupies the space of 6 relay mounting plates.

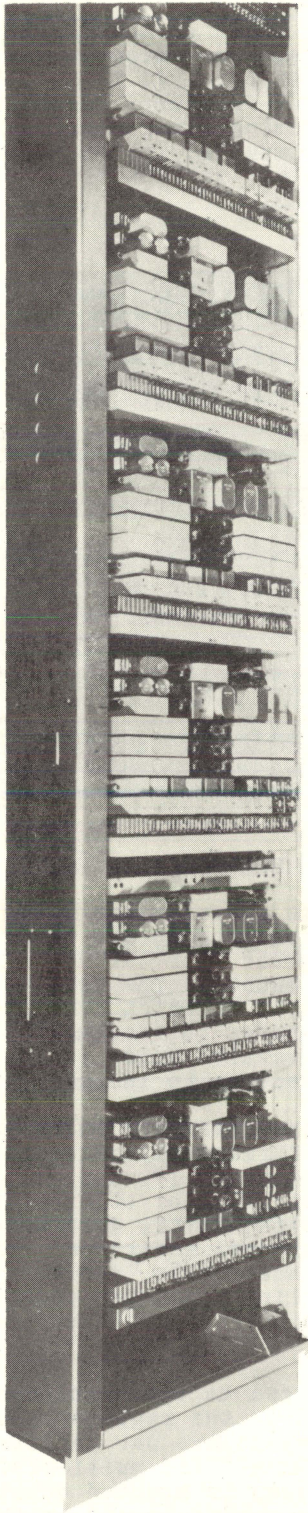

Fig. 45 - Multi-Frequency Receiver Frame

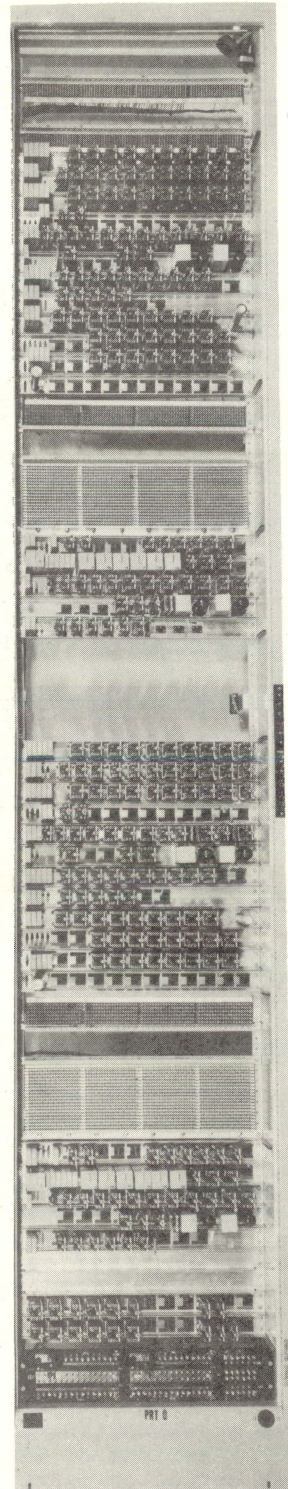

Fig. 46 - Pretranslator Frame

The pretranslator circuit determines from the first two or three digits dialed the total number of digits to be expected on any one call. In some areas the same number of digits is always dialed and the register is arranged to seize the marker as soon as this number of digits has been received. In many areas, however, the number of digits to be dialed varies for different called offices and pretranslation becomes necessary. Where the numbering arrangement is simple the register may be arranged to do the necessary

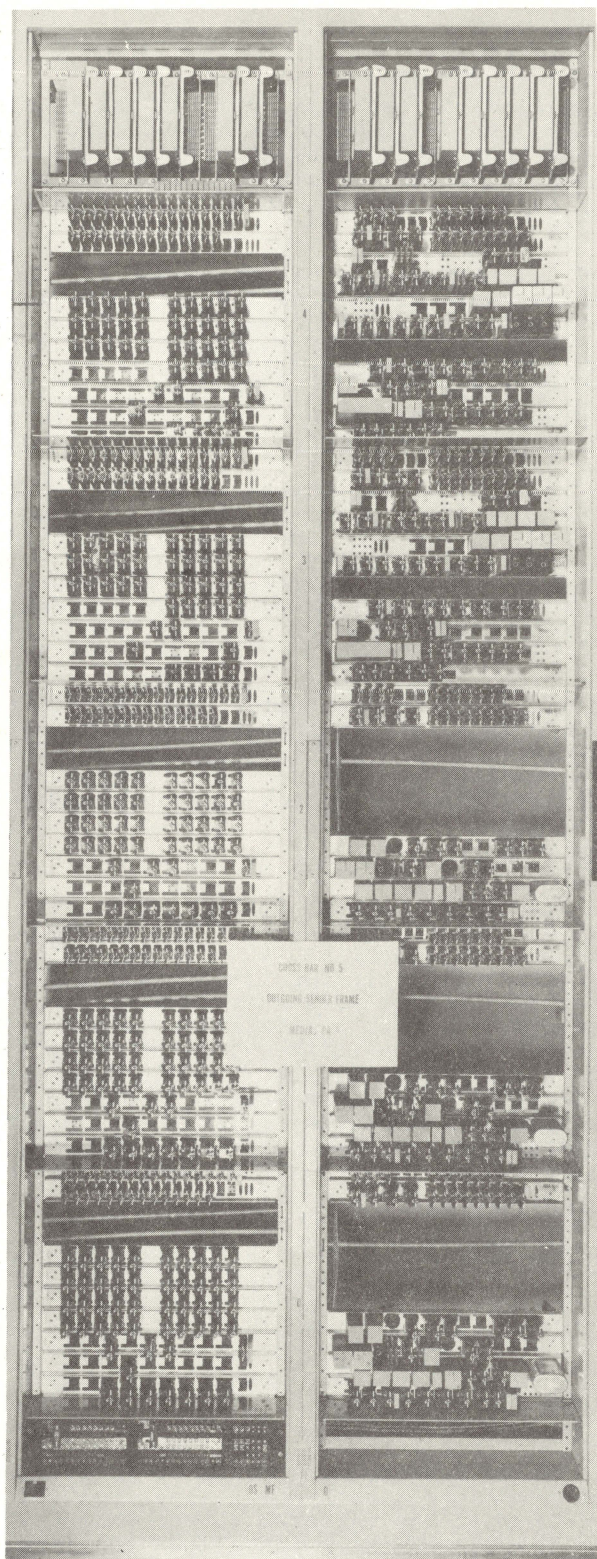

Fig. 47 - Multi-Frequency Outgoing Sender

called telephone number to a crossbar, crossbar tandem, or crossbar toll office, in the form of multi-frequency pulses. It is also used to record the calling and called line information on a call from an AMA subscriber to any of these offices. The multi-frequency outgoing sender is composed of 3 types of units, 2 of which are provided in all senders and the third being provided in quantities depending upon the number of digits to be accommodated. Each sender requires an alternating current supply of 6 different

pretranslation for itself. In most situations, however, it is more economical to concentrate the pretranslating functions in separate pretranslator circuits which may be used in common by all originating registers. A pretranslator connector circuit, furnished once for each pretranslator, serves to connect its pretranslator to an originating register momentarily after the first two or three digits have been dialed. One pretranslator can carry the traffic in most offices, two being sufficient for a marker group in any case and since one additional circuit is provided for maintenance security there will always be at least two pretranslators in an office.

Section 8. Outgoing Sender (OS) Frames

The Outgoing Sender frame is a two bay framework mounting 5 senders with each sender extending across both bays. Each bay is also equipped with a fuse panel at the bottom, a multi-contact relay unit at the top and a miscellaneous equipment mounting plate just below the latter. Outgoing senders are of four types, classified according to the manner in which they transmit their information to the called office. These 4 classes are: dial pulse, multi-frequency pulse, revertive pulse, and relay call indicator pulsing. The outgoing senders mounted on one frame may be any combination of the 4 classes.

The Dial Pulse Outgoing Sender is used to transmit the called telephone number to a step-by-step or other type office in the form of pulses similar to those generated by a dial. The dial pulse outgoing sender is also used in recording the calling and called line information on a call to a step-by-step number from an AMA subscriber. The dial pulse outgoing sender is composed of 4 surface wired units, 3 of which are provided in all senders and the fourth being provided in quantities according to the number of digits to be accommodated. Outgoing dial pulse senders are wired to outgoing sender link frames for connection to outgoing trunks.

The Multi-Frequency Outgoing Sender (Fig. 47)

is used to transmit the

frequencies which are used in various combinations of two at a time for the 10 digits, 0 to 9, the start signal and the end signal. These 6 frequencies are 700, 900, 1100, 1300, 1500 and 1700 cycles per second and are generated by the Multi-frequency Current Supply Unit (MFCS) mounted on a miscellaneous relay rack. Each MFCS unit can serve a maximum of 42 senders. The multi-frequency outgoing senders are wired to outgoing sender link frames for connection to outgoing trunks.

The Revertive Pulse Outgoing Sender is used to transmit the called number to a panel or crossbar No. 1 office by counting the pulses which revert back to it from the panel selector commutator or the crossbar terminating sender. The revertive pulse outgoing sender is also used to record the calling and called line information on a call from an AMA subscriber to a panel or crossbar office. This sender is composed of 4 units, 3 of which are furnished on all senders and the remaining one furnished in quantities depending upon the number of digits to be accommodated. The revertive pulse outgoing senders are wired to outgoing sender link frames for connection to outgoing trunks.

The Call Indicator Outgoing Sender is used to transmit the called number to a manual or panel sender tandem office in the form of polarized, marginal, direct current pulses. It is also used to record the calling and called line information on a call from an AMA subscriber to a manual office or through a panel sender tandem office. The sender is composed of 4 units, 3 of which are furnished in all senders and the remaining one being furnished according to the number of digits which must be accommodated. The call indicator outgoing senders are wired to the outgoing sender link frame for connection to outgoing trunks.

Outgoing senders of all types are wired to the multi-contact relay units at the top of the sender frames for connection to the sender end of the associated outgoing sender connector. Two multi-contact relays per sender are required to accommodate up to 11 digits and when calls from AMA subscribers are to be served additional sender connector relays mounted on the Axiliary Outgoing Sender Connector (AOSC) frame are required.

#### Section 9. Inter-Marker Group Sender (IMGS) Frames

The Inter-Marker Group Sender frame is a single bay framework mounting 6 senders without AMA or 4 senders with AMA at the bottom and 2 multi-contact relay units at the top for association with a maximum of 2 outgoing sender connectors and 2 incoming register marker connectors. They are of 2 types: subscriber-to-subscriber, for handling calls from a subscriber in one marker group to a subscriber in another marker group in the same building, and subscriber-to-trunk for handling calls from a subscriber in one marker group to a trunk in a second marker group in the same building. The inter-marker group sender is capable of accepting a maximum of 9 digits and may be wired to outgoing sender link frames for connection to outgoing trunks, to outgoing sender connector frames for marker access in the calling marker group and to incoming register marker connector frames for marker access in the called marker group.

#### Section 10. B Sender and Position Finder (SPF) Frames

The Central B Sender and Position Finder frame is a single bay bulb angle framework mounting 4 B senders at the bottom of the frame and the associated 4 position finders at the top, capable of associating each sender with any one of 20 Dial System B Switchboard (DSB) positions. Each central B sender is permanently associated with a central B incoming register located in the number 5 office and connected to it over 4 leads. The DSB switchboard and the sender and position finder frames serving the number 5 office may or may not be located in that number 5 office.

The B sender and position finder along with the associated DSB switchboard equipment is used to establish a connection between a central B incoming register in a number 5 office and a DSB operator. This connection completes a path which also includes a manual incoming trunk and incoming register link in the number 5 office which places the manual A operator in communication with the DSB operator and allows the former to pass the called telephone number to the latter who then may operate keys in her switchboard position which will store the called telephone number in the central B sender. The number is then revertive pulsed from the central B sender into the number 5 central B incoming register and the call proceeds to completion on a mechanical basis.

Section 11. Incoming Register Link  
(IRL) Frames

The Incoming Register Link Frame (Fig. 48) is a single bay framework mounting, from top down, a row of 5 terminal strips, 5 two-hundred point 6 wire crossbar switches, 5 trunk preference relay units, 10 register preference relay units, 10 trunk number relay units, and a fuse panel. The crossbar switches are furnished once per 20 trunks as are the associated trunk preference relay units and terminal strips. The register preference and trunk number relay units are furnished once per register.

The incoming register link frame is used for connecting incoming trunks to incoming registers with each frame accommodating 100 trunks and 10 registers. The 100 trunks are wired to the vertical units of the link switches and the 10 registers are multiplied to the 10 horizontal circuits of all switches. Only one type of incoming register may be served by one incoming register link frame and separate frames are required for each type. When more than 100 trunks can be loaded on 10 registers, which is the general case with the multi-frequency type, a Supplementary Incoming Register Link (SIRL) frame is provided and arranged to accommodate an additional 100 trunks with a multiple appearance of the same 10 incoming registers. The supplementary incoming register link frame is a single bay framework identical in appearance to the basic frame except that the register preference and trunk number relay units are omitted.

Section 12. Coin Supervisory Link (CSL)  
Frames

The Coin Supervisory Link frame closely resembles the IRL frame of Fig. 47, and is a single bay framework mounting, from the top down, a row of 5 terminal strips, five 200 point 6 wire switches, 5 trunk preference relay units, 10 register preference relay units, and a fuse panel. The crossbar switches are furnished once per 20 trunks, as are the associated trunk relay units and terminal strips. The register preference relay units are furnished once per supervisory circuit.

The coin supervisory link frame is used for connecting outgoing trunks arranged to serve coin subscribers to coin supervisory circuits. Each frame will accommodate 100 coin trunks wired to the vertical units of the link switches and 10 coin supervisory circuits multiplied to

the 10 horizontal circuits of all switches. When more than 100 coin trunks can be loaded on 10 coin supervisory circuits a Supplementary Coin Supervisory Link (SCSL) frame is provided and arranged to accommodate an additional 100 coin trunks with a multiple appearance of the same 10 coin supervisory circuits. The supplementary coin supervisory link frame is a single bay framework identical in appearance to the basic frame except that the register preference relay units are omitted.

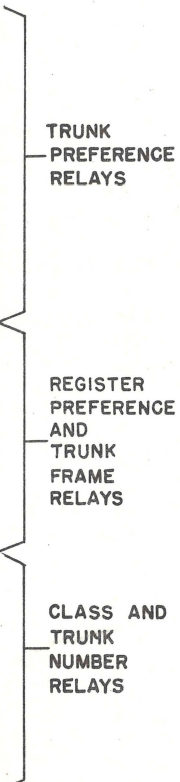
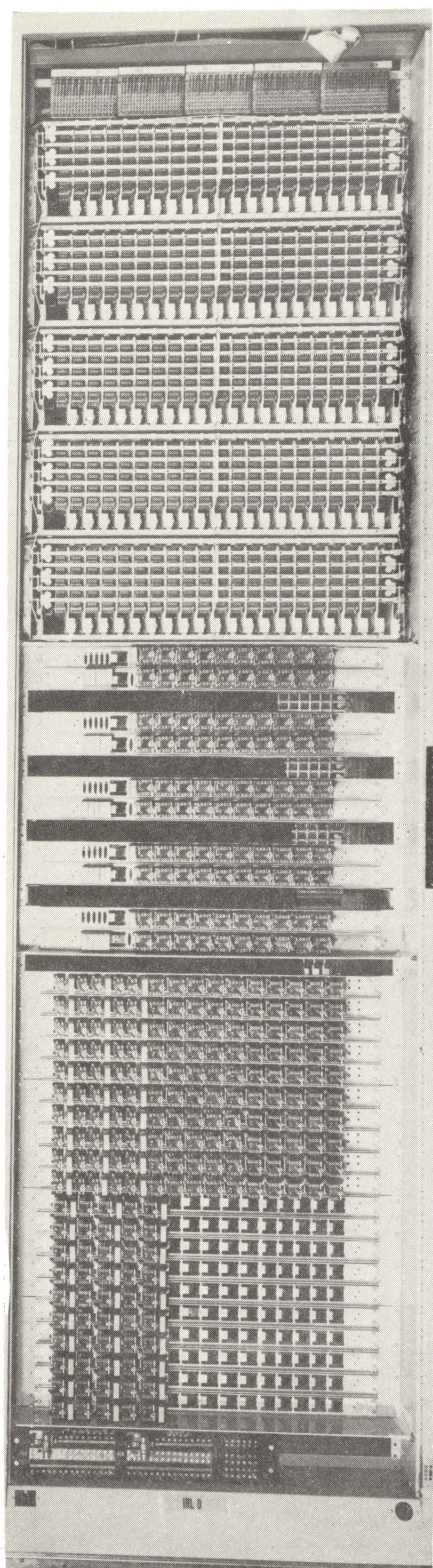

Fig. 48 - Incoming Register Link Frame

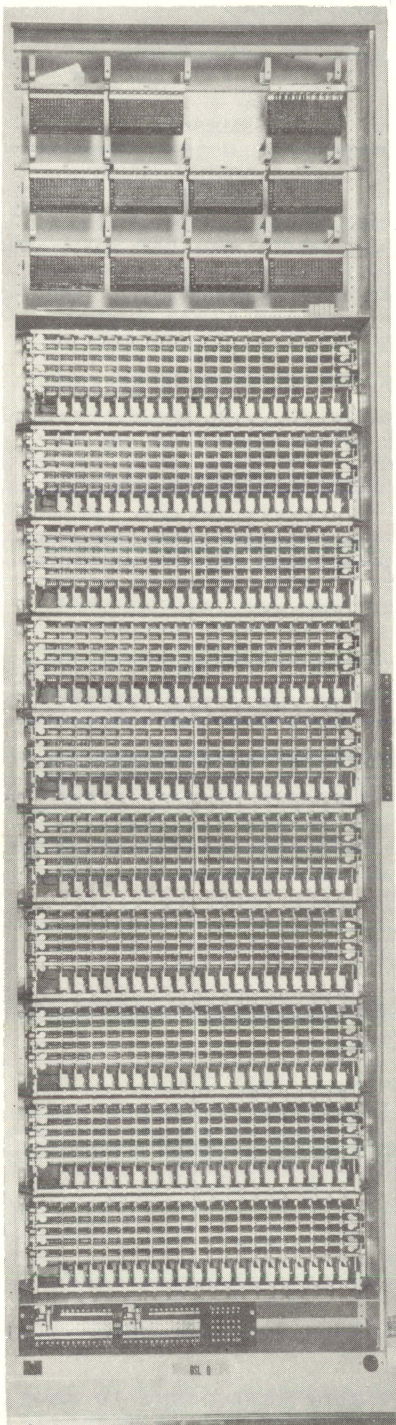

Fig. 49  
Outgoing Sender Link Frame

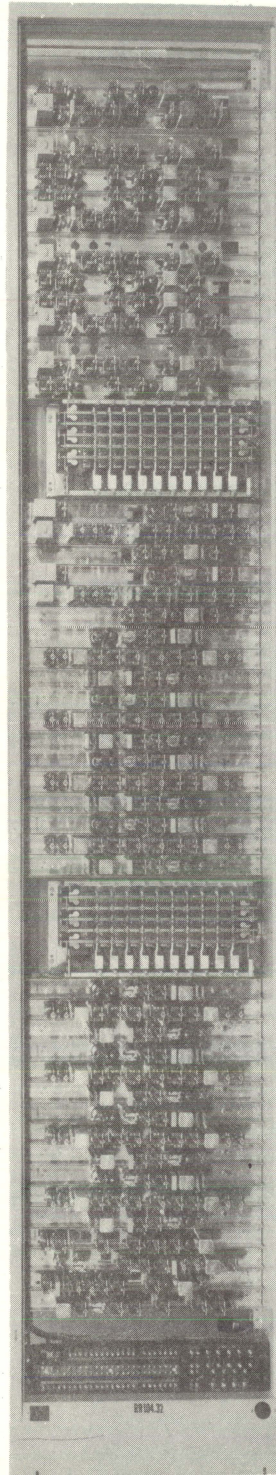

Fig. 50  
Relay Rack Frame for Trunks Requiring Ringing

Section 13. Outgoing Sender Link (OSL) Frames

The Outgoing Sender Link frame (Fig. 49) is a single bay framework mounting ten 6 wire 200 point crossbar switches, a fuse panel, and 11 terminal strips. Ten terminal strips provide the cross-connection facilities for 200 trunks and 200 vertical units at 6 wires per cross-connection while the remaining terminal strip carries miscellaneous other circuits.

The outgoing sender link frame is used to connect outgoing senders to outgoing trunks or to AMA intra-office trunks. The frame will accommodate 200 trunk circuits wired to the vertical units of the link switches and each switch will accommodate 10 outgoing senders wired to the horizontal circuits. The 10 horizontals of a switch may be multiplied as required to the similar horizontals of other outgoing sender link frames to fully load a group of 10 senders. The 20 outgoing trunks appearing on the vertical units of one link switch must all appear on the same trunk link frame and not more than 60 trunks on one trunk link frame may appear on any one outgoing sender link frame. When the 20 trunks appearing on one link switch require different types of outgoing senders the horizontal circuits are split and the proper type senders are wired to the split horizontals. Trunks appearing on vertical units to the left of each split then have access to the one type of sender and trunks appearing on vertical units to the right of the split have access to another type of sender.

Section 14. Trunk Relay Rack (RR) Frames

The trunk relay rack frame (Fig. 50) is a single or double bay framework, each bay mounting a fuse panel at the bottom and providing mounting space for all types of trunks, for a talking battery filter (Fig. 32) supplying quiet talking battery to those trunks, and for the ringing selection switches associated with the incoming and intra-office trunks. One ringing selection switch serves the ten trunks assigned to identical appearances on the ten switches of one trunk link frame, the trunks being wired to the vertical units. The various ringing combinations are wired to the horizontals of the ringing selection switches and the connection of ringing voltage to an incoming or intra-office trunk is accomplished through a set of cross-points on the switch. Equipment for the ten incoming or intra-office trunks associated with one ringing selection switch is mounted directly below that switch. The capacity of a relay rack frame for these types of trunks is therefore 30 trunks when two circuits occupy three mounting plates, and 20 trunks when one circuit occupies two mounting plates. Other type trunks are mounted in the upper portion of the frame as space permits, with the timers associated with trunks arranged for overtime operation mounted at the top of the frame.

Section 15. Number Group (NG and TNG) Frames

The Number Group frame (Fig. 51) is used by the marker as a sort of electrical card index to determine the location of the line link vertical unit assigned to any given

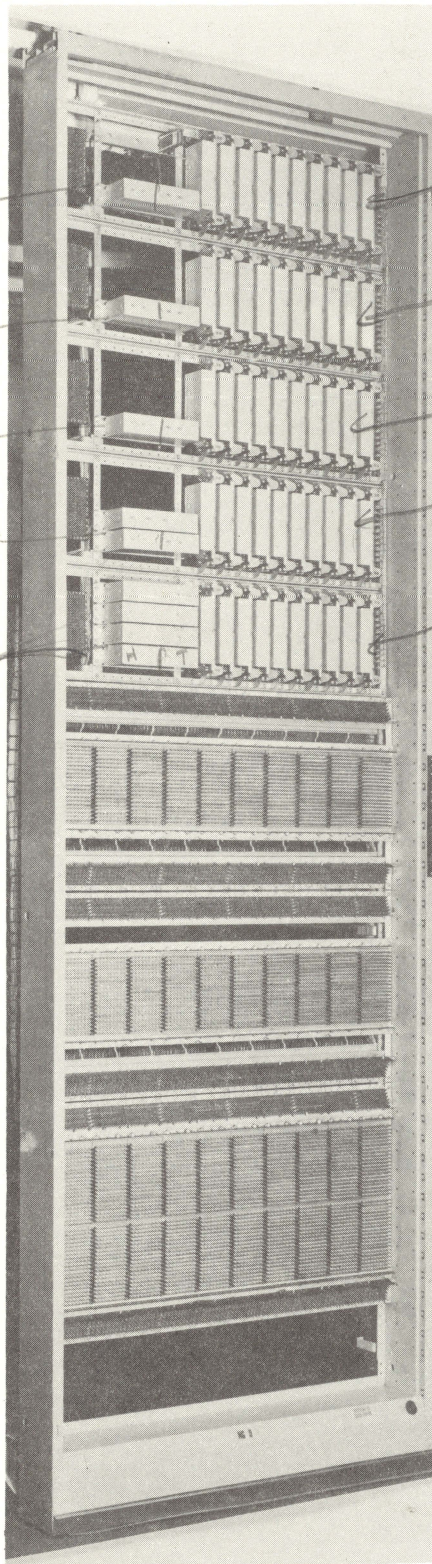

Fig. 51 - Number Group Frame

number of completing type trunk, and to determine the type of ringing to be applied on the line for ringing the given number.

The Line Number Group (NG) frame is a single bay framework the top half of which is occupied by 5 units containing both multi-contact and U relays and the bottom half by 3 cross connecting fields. These fields provide space for 3 cross-connections per telephone number. The 5 relay units mount a total of 100 tens-block relays, each one being a half multi-contact relay, ten hundreds-block U type relays, ten units U type relays and some miscellaneous U type relays mounted on the remaining horizontal mounting plates. Associated with the cross-connecting fields and mounted on the rear of them are several hundred 2-watt composition resistances. Each number group frame will serve 1,000 consecutive telephone numbers. The frames are numbered according to the thousands digit of the telephone numbers whose three locating cross-connections appear on the frame. A maximum of 20 line number group frames with 20,000 directory numbers can be associated with one marker group in one office.

The Trunk Number Group (TNG) frame is a single bay framework equipped in identical manner to the line number group frame with some minor changes in the miscellaneous U type relays mounted on the horizontal mounting plates. The cross-connecting fields provide space for 3 cross-connections per completing type trunk. This type of trunk requires a line link appearance in addition to its trunk link appearance for use when connecting the completing type trunk to an outgoing trunk and location of that line link appearance is furnished to markers by the trunk cross-connections on the (TNG) frame. Trunk number group frames are furnished in pairs and are numbered starting with (0) and (1). Each pair of trunk number group frames will serve 1000 trunks.

#### Section 16. Master Test (MTF) Frames

The Master Test frame performs 3 principle functions: (1) to test markers, senders, registers, trunks, transverters, and other connecting circuits, (2) to automatically record troubles encountered by a marker during the establishment of service and test calls, (3) to automatically monitor the actions of senders and registers in service. The master test frame consists of the following 7 bays of equipment: one recorder bay, two control bays, one jack bay, two register and sender test bays and one automatic monitor bay. The first four bays (Fig. 52) are always located adjacent to each other in the maintenance center area of the central office building. The remaining three bays (Fig. 53 & 54) contain only relay equipment and, while locating them in the maintenance center area is desirable from a cabling standpoint, they may be located in any convenient nearby area.

The Recorder Bay (Fig. 52) is equipped with a trouble recording perforator and its two associated relay control units, a plant register unit, a timer for the trunk test circuit, a fuse panel, four frame terminal strips, and a time of day unit if required. The perforator unit, used by markers in trouble to record the operated and non-operated condition of the marker relays at the instant of a call failure, is mounted about shelf high in the bay and is operated on a plug-in basis by means of eighteen 20 conductor plugs for control leads, and a 48 volt DC and 110 volt AC power supply plug. The plant register unit, mounting a number of registers used by the plant forces to count various equipment over-loads and failures, is mounted just above the card perforator at about eye level for convenience in reading. The two trouble recorder control relay units mounted above the plant register unit are followed by a time of day unit required when AMA equipment is not furnished. Mounted in the bottom of the bay immediately over the fuse panel is the timer and associated drive used for trunk test. The motor driving the timer is operated on 22 volt AC. The motor driving the card perforator is a duplex type arranged to start on 48 volts DC, automatically transferring to a running condition upon application of 110 volts AC. Upon failure of the 110 volt AC supply the motor will automatically transfer to a running condition on 48 volts DC.

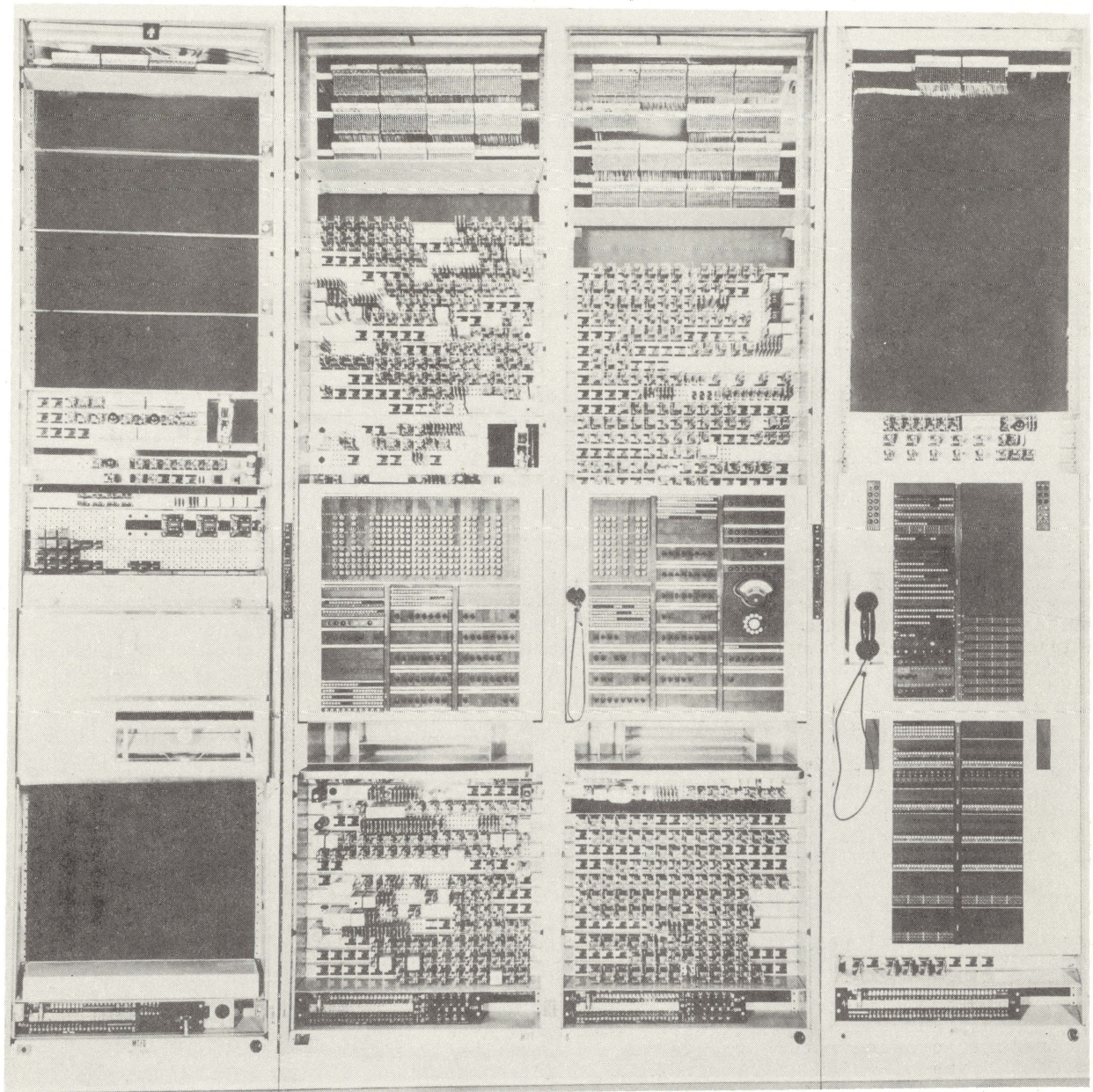

RECORDER BAY

CONTROL BAYS

JACK BAY

Fig. 52 Maintenance Center Portion of Master Test Frame

The Control Bays (Fig. 52) are equipped with writing shelves at desk height above which are mounted jack, key and lamp panels followed by various relay units and terminal strips. Below the writing shelves are other relay units and two fuse panels. The jack, key and lamp panels contain the control keys and lamps associated with the master test control, the voltmeter test, register and sender test, automatic monitor, and trouble recorder circuits. A dial is provided in the right hand control bay just below the voltmeter for use with the telephone circuits appearing on keys and lamps above the voltmeter. These telephone circuits provide communication between the maintenance center and points both inside and outside the central office. The receiver provided in the right-hand bay is used to check for dial tone on registers. The push-button type keys extending across the top of the panel in the left-hand bay and across part of the top of the panel in the right-hand bay are used to pre-set the test conditions to be applied to a marker or other circuit during a test call.

The Jack Bay (Fig. 52) is equipped with two fields of jacks, one field above and the other below the writing shelf level. The lower field contains the jacks, keys, and lamps used to impose a make-busy condition upon connectors, registers, and senders, and to impose test and make-busy conditions on plugging-up lines, common overflow trunks, and permanent signal holding trunks. The upper field mounts the jacks, keys, and lamps, used to impose make-busy conditions on markers, to impose test and make-busy conditions on outgoing trunks, and to observe various load and progress conditions in markers and AMA equipment. Below the jack fields is mounted a plate of relays and a fuse panel while above there appears three more plates of relays and two terminal strips. The handset mounted in the jack bay is for use with the telephone circuits appearing on keys and lamps in the right hand control bay.

The Automatic Monitor Bay (Fig. 53) is equipped from the bottom up with a fuse panel, various relay units, a multi-contact relay unit and three terminal strips. The principal action of the equipment on the automatic monitor bay is the automatic monitoring of service calls which consists of verifying the accuracy of information given out by registers and senders as compared with the instructions given into those circuits. In addition, the automatic monitor bay may also summon the trouble recorder to produce a perforated card record when monitoring reveals unsatisfactory action by a register or sender.

The Register and Sender Test Bays (Fig. 54) are equipped from the bottom up with a fuse panel, various relay units including a multi-contact relay unit and two rows of terminal strips. Included with the relay units of the right-hand bay are also two cross-connection type terminal strips. The equipment of the register and sender test bay, working with that of the automatic monitor bay, transmits test-call information into registers and senders while simulating the worst possible service conditions and, under these same conditions tests the circuits for their ability to give out accurate information.

#### Section 17. Connector Frames

Connector frames all perform the same general function of closing through the many control leads needed between a marker serving a call and the various link and equipment frames involved in that call. All connector frames may be divided into two classes according to the direction of traffic through them and are named to assist in identifying that direction. When a link or equipment frame seeks a marker, the direction of this traffic being toward the marker, connection is established through a marker connector frame of which there are three: (1) originating register marker connector frame, (2) incoming register marker connector frame, (3) line link marker connector frame. When a marker seeks a link or equipment frame, the direction of this traffic being away from the marker, a connector frame is used of which there are four: (1) trunk link connector frame, (2) line link connector frame, (3) number group connector frame, (4) outgoing sender connector frame.

Connector frames generally mount all of the equipment necessary to complete from one to four connector circuits. Notable exceptions to this are the 3 cases of the originating register marker connector, the incoming register marker connector, and the outgoing sender connector, where the multi-contact relays at one end of the connector are mounted on the originating register, incoming register, and outgoing sender frames respectively. Such connectors are known as double ended connectors and establishing a path through one of them requires the simultaneous operation of multi-contact relays on both the equipment frame and the connector frame.

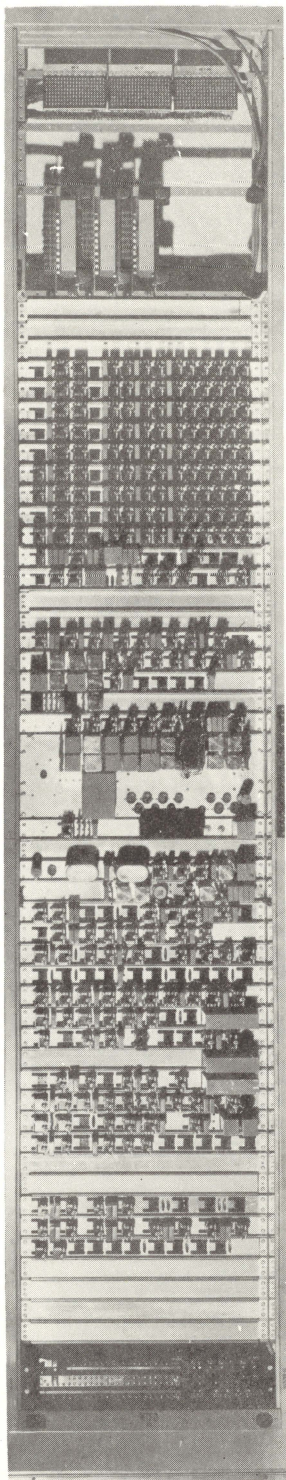

Fig. 53 - Automatic Monitor  
Bay of Master Test Frame

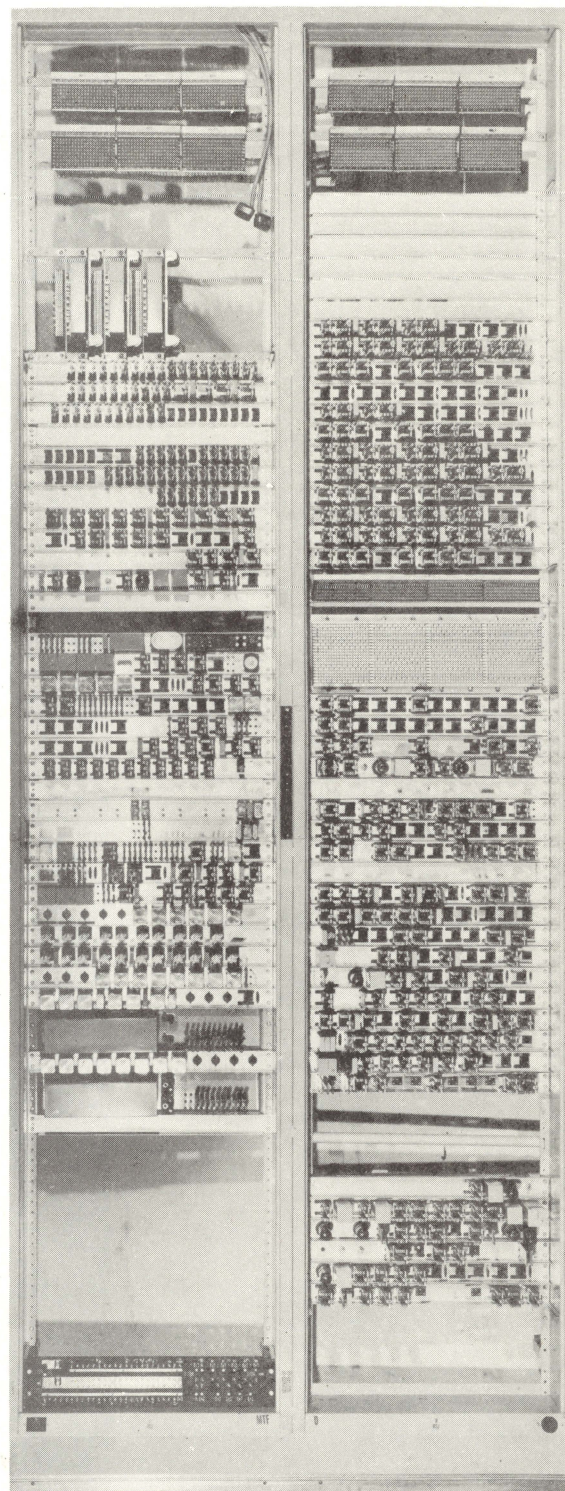

Fig. 54 - Register and Sender Test  
Bays of Master Test Frame

Each connector frame is a single bay framework mounting multi-contact type relay terminal strips at the top, a fuse panel at the bottom, and from one to 4 connectors depending upon the size and type. Each connector will serve up to 6 markers.

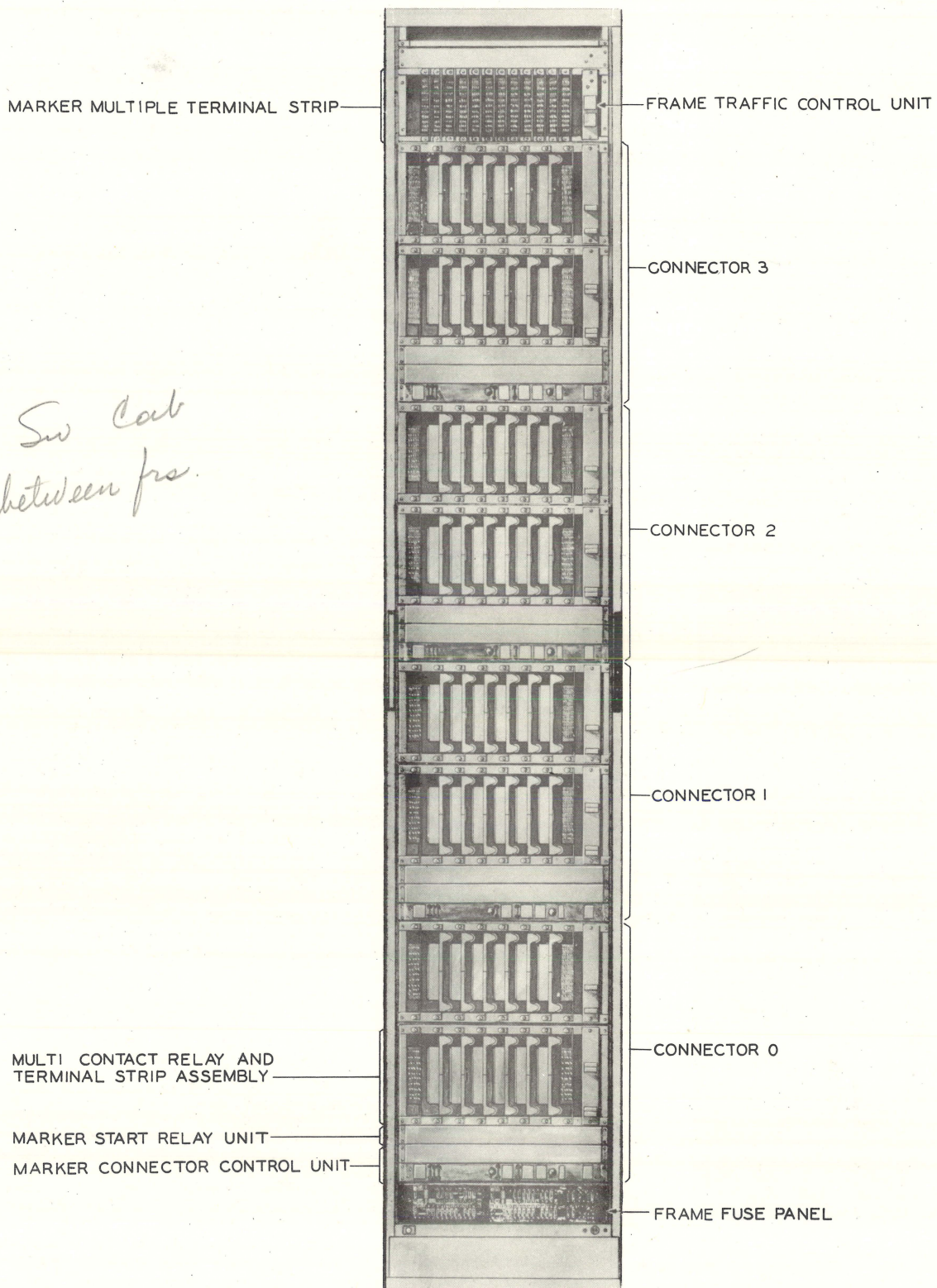

Fig. 55 - Originating Register Marker Connector Frame

Section 18. Originating Register Marker Connector (ORMC) Frame.

The Originating Register Marker Connector frame (Fig. 55) is used by an originating register, which contains a completely dialed number, to seek and connect to an idle marker. The basic frame will accommodate six markers and additional markers up to twelve total require a Supplementary Originating Register Marker Connector (SORMC) frame. In addition, an Auxiliary Register Marker Connector (ARMC) frame will be required for each basic and supplementary originating register marker connector frame on jobs equipped to handle 9, 10, and 11 dialed digits. The basic frame accommodates one end of four double-ended connectors, one frame traffic control unit, plus a marker start and a connector control unit for each connector. The supplementary frame, when provided accommodates the extension of the same four connectors as appear on its associated basic frame and is equipped with a marker start unit per connector. Each connector is equipped with two 60 point multi-contact relays per marker on the basic and supplementary frames plus two half 60 point multi-contact relays on the auxiliary frame, one half furnished once per register and the other furnished once per marker. Each connector will serve up to 20 originating registers depending upon the calling rate and a minimum of two connectors per office is always furnished for safety reasons in case of trouble in a connector. The marker connector control unit assists the connector in the selection of an idle marker when signaled by an originating register. The frame traffic control unit, working with the connector control unit and a master traffic control unit, establishes an order of serving calls that assures all connectors being served uniformly. The frame fuse panel mounts a split 48 volt bus-bar, with half of the markers which are served by each connector being wired on each side of the split, and a 130 volt bus-bar for vacuum tube supply.

Section 19. Incoming Register Marker Connector (IRMC) Frame.

The Incoming Register Marker Connector frame, identical in appearance to the ORMC frame of Figure 55, is used by an incoming register or an inter-marker-group sender to seek and connect to an idle marker after the register or sender has received the called number. The basic frame will accommodate the first 6 markers and additional markers to 12 total require a Supplementary Incoming Register Marker Connector (SIRMC) frame. In addition, an Auxiliary Register Marker Connector (ARMC) frame will be required for each basic and supplementary frame on jobs equipped to handle 9, 10, and 11 dialed digits. The basic frame accommodates one end of four double-ended connectors and one frame traffic control unit, and for each connector a marker start and a connector control unit. The supplementary frame, when provided, accommodates the extension of the same four connectors as appear on its associated basic frame and is equipped with a marker start unit per connector. Each connector is equipped with two 60 point multi-contact relays per marker on the basic and supplementary frames plus two half 60 point multi-contact relay. One half furnished once per register and the other furnished once per marker. The originating register half-relay is mounted on the auxiliary register marker connector frame, while the incoming register half-relay is mounted on the incoming register frame.) Each connector will serve any number of incoming registers and inter-marker-group senders depending upon the calling rate, and a minimum of two connectors per office is always furnished for safety reasons in case of trouble in a connector. The marker connector control unit assists the connector in selecting an idle marker when signaled by an incoming register or inter-marker-group sender. The frame traffic control unit working with the connector control unit and a master traffic control unit establishes an order of serving calls that assures all connectors being served uniformly. The frame fuse panel mounts a split 48 volt bus-bar with half of the markers which are served by each connector being wired on each side of the split and a 130 volt bus-bar for vacuum tube supply.

Section 20. Line Link Marker Connector (LLMC) Frames.

The Line Link Marker Connector frame, similar in appearance to the ORMC of Figure 55, is used by a line link frame to seek and connect to a marker when the line link contains a calling line waiting for dial tone. The basic frame will accommodate the first 6 markers and additional markers up to 12 total require a Supplementary Line Link Marker Connector (SLLMC) frame. The basic frame accommodates four connectors and one frame traffic control unit, and for each connector a marker start and a connector control unit. The supplementary frame, when provided, accommodates the extension of the four connectors which appear on its associated basic frame and is equipped with a marker start unit per connector. Each connector is equipped with one full and one-half 60 point multi-contact relay per marker and serves one line link frame. The marker connector control unit assists the connector in selecting an idle marker when signaled by the line link frame. The frame traffic control unit, working with the connector control and the master traffic control units, establishes an order of serving calls that assures all connectors being served uniformly. The frame fuse panel mounts a split 48 volt bus-bar with half of the markers which are served by each connector being wired on each side of the split, and a 130 volt bus-bar for vacuum tube supply.

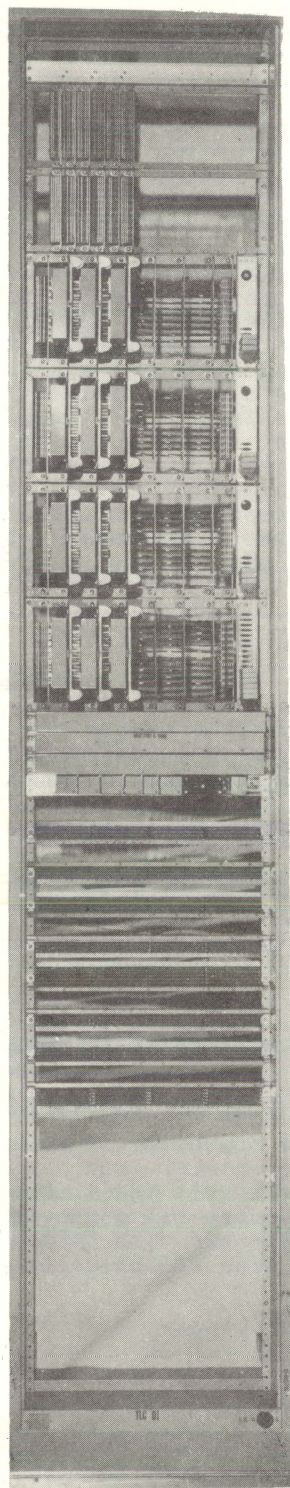

Fig. 56  
The Trunk Link Connector Frame

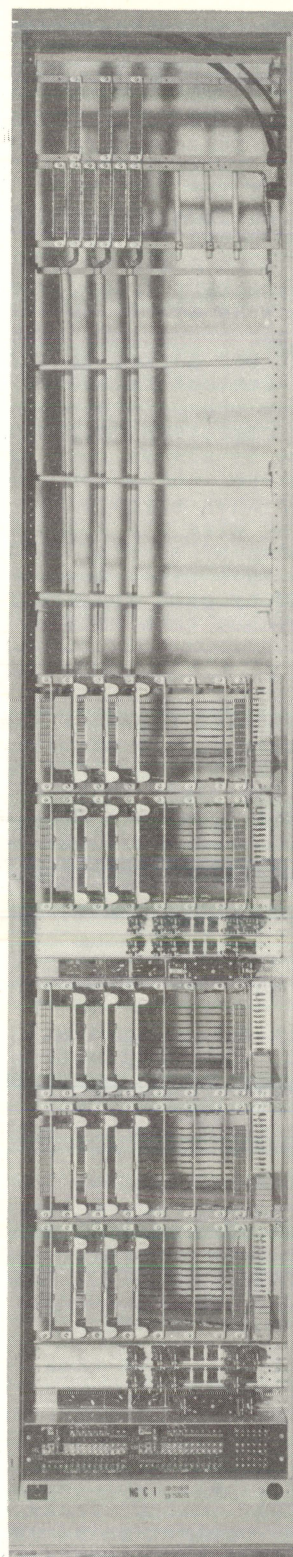

Fig. 57  
Number Group Connector Frame

Section 21. Trunk Link Connector (TLC) Frame.

The Trunk Link Connector frame (Fig. 56) is used by a marker for connecting to a trunk link frame when seeking trunks or originating registers and when building channels between lines and those trunks or registers. The basic frame will accommodate the first 6 markers and additional markers up to 12 total require a Supplementary Trunk Link Connector (STLC) frame. The basic frame contains one single ended connector, while the supplementary frame accommodates the extension of two single ended connectors, each connector serving one trunk link frame. A marker preference unit and a connector control unit is furnished per connector circuit and with a trunk terminating and cross-connecting field, is mounted on the basic frame. Only the marker preference unit is repeated on the supplementary frame. Each connector is equipped with four 60 point multi-contact relays per marker. The marker preference and connector control units serve to admit only one marker at a time to a connector and its associated trunk link frame during the instant cross-points are being established for a call path. The close association and large amount of wiring between the basic trunk link connector frame and its associated trunk link frame makes it necessary that the two be always located adjacent with the connector frame on the right.

Section 22. Line Link Connector (LLC) Frame.

The Line Link Connector frame, similar in appearance to the ORMC of Fig. 55, is used by a marker for connection to a line link frame when seeking lines, both called and calling, and when building channels between those lines and trunks or registers. The basic frame will accommodate the first 6 markers and additional markers up to 12 total require a Supplementary Link Link Connector (SLLC) frame. The basic and supplementary frames contain 4 single ended connectors serving 4 line link frames. A marker preference and a connector control unit per connector are furnished on the basic frame with only the marker preference unit repeated on the supplementary frame. The marker preference and connector control units serve to admit one marker at a time to a line link connector and its associated line link frame during the instant of establishing the crosspoints for a call. Each connector is equipped with two 60 point multi-contact relays per marker. The frame fuse panel mounts a split 48 volt bus-bar with half of the markers which are served by each connector being wired on each side of the split.

Section 23. Number Group Connector (NGC) Frame

The Number Group Connector frame (Fig. 57) is used by a marker for connection to a number group or trunk number group frame when seeking the line link frame location and ringing information about a called number or a completing-type toll or tandem trunk. The basic frame will accommodate the first 6 markers and additional markers up to 12 total require a Supplementary Number Group Connector (SNGC) frame. The basic and supplementary frames contain 3 single ended connectors each serving one number group of one thousand telephone numbers. A marker preference and a connector control unit are furnished once per connector circuit and mounted on the basic frame with only the marker preference unit repeated on the supplementary frame. Each connector is equipped with two one-half 60 point multi-contact relays per marker, connector circuits zero and one sharing a full multi-contact relay for their individual half relays. The frame fuse panel mounts a split 48 volt bus-bar with half of the markers which are served by each connector being wired on each side of the split.

Section 24. Outgoing Sender Connector (OSC) Frame

The Outgoing Sender Connector frame (Fig. 58) is used by a marker, containing a call which required a sender, to locate and connect to an outgoing sender of the proper type. The basic frame will accommodate the first 6 markers and additional markers up to 12 total require a Supplementary Outgoing Sender Connector (SOSC) frame. The basic and supplementary frames contain one end of two double ended connectors with each connector having access to a maximum of ten senders, such as multi-frequency, reverive pulse, etc. A marker preference unit and a connector control unit are furnished once per connector and mounted on the basic frame, with only the marker preference unit repeated on the supplementary frame. Two connectors occupy the top halves of both the basic and supplementary frames while the lower halves mount the sender and sender group relays with associated cross-connecting terminal strips. The sender group relays are furnished two per marker per sender group while the sender relays are furnished once per marker per sender. When calls from AMA lines are to be served additional equipment per connector is required and mounted on an Auxiliary Outgoing Sender Connector (AOSC) frame.

Section 25. Master Test Connector (MTC)  
Frame

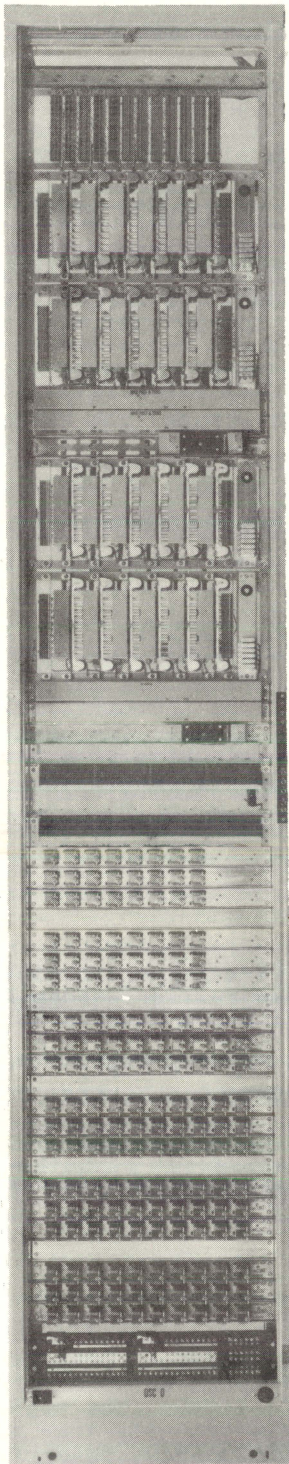

The Master Test Connector frame consists of two bays of equipment capable of connecting a maximum of 6 markers to the master test frame and trouble recorder. Additional markers up to 12 total require two Supplementary Master Test Connector (SMTC) frames and on installations equipped for AMA an Auxiliary Master Test Connector (AMTC) frame is required. Each bay of the master test connector frame is equipped with 8 multi-contact relay and terminal strip units arranged for 6 relays, a scanning relay unit arranged for 9 multi-contact relays, a 234 type terminal strip for connecting miscellaneous cabling to the frame, 7 mounting plates of control relay equipment, and a fuse panel. Connection through a master test connector circuit may be made in either of two directions; (1) from a marker in trouble desiring the trouble recorder or (2) from the master test frame desiring access to markers, senders, registers, or AMA equipment for test.

Fig. 58  
Outgoing Sender Connector Frame

CHAPTER V

OPERATING FEATURES

Section 1. General

Dial Telephone Systems in general use today all employ mechanical motion for various switching functions, this motion being controlled by magnetically operated ratchets or by motor driven rods or shafts. The Crossbar Dial Systems also employ mechanical motions for the switching functions but this motion has been reduced to that required to close or open relay contacts. The moving rods and shafts, and their associated motor drives, as well as the magnetically operated ratchets have been eliminated. Power driven equipment in the crossbar system includes only the battery charging machines, the ringing and tone supply machines and the timers used to time calls.

The Crossbar switch is the principle switching device employed in Crossbar Dial Systems and uses the mechanical motion provided by the magnet and armature combinations, mounted in its frame, to bring the contact springs, also mounted there, into contact with each other. By means of various inter-connections of the horizontal and vertical circuits through successive crossbar switches telephone traffic switching requirements can be satisfied.

Section 2. General Switching Plans

Interconnection of Crossbar switches is accomplished through two or three wire circuits to which the following names apply:

- (a) Link Circuit is a path, 3 wires unless otherwise specified, between two crossbar switches within one frame.
- (b) Junctor Circuit is a three wire path between two crossbar switches on two different frames both in the same office.
- (c) A Trunk Circuit is a two wire path between two crossbar switches (assuming a crossbar to crossbar call) located on two different frames in two different offices.

The pattern followed in the interconnecting of crossbar switches is, in the case of link circuits, called the spread and in the case of junctor circuits is called a distribution. These patterns associated with the vertical and horizontal circuits of their crossbar switches provide the access of one circuit to many when traffic is branching out, and the access of many circuits to one when traffic is concentrating.

The Crossbar switch vertical unit contains one vertical circuit capable of connection to any one of ten horizontal circuits and consists essentially of ten levels of spring combinations each level containing either 3, 4 or 6 spring pairs. Each spring pair in a level (Fig. 59A) is made up of one movable and one stationary spring arrangement, the movable springs being individual and the stationary spring being part of a vertical nickel strip common to all the spring pairs in a vertical unit. (Fig. 59B) represents a three wire vertical unit, which contains three pairs of springs per level. The circuit convention used to represent one vertical unit of any number of spring pairs is shown in (Fig. 59C) and it will be seen that only the first and last of the ten horizontals from 0 to 9 are indicated.

A 100 point crossbar switch is represented in (Fig. 59D), with the first and last of its 10 vertical units and the first and last of its 10 horizontals or levels shown. The 10 vertical units in a 100 point crossbar switch are designated 0 to 9 from left to right looking at the equipment side. The 10 levels of each vertical unit in (Fig. 59D) are represented as being multiplied horizontally to the same levels of each other vertical unit, so that circuits wired individually to the 10 vertical units could have access to circuits wired to any one of the ten levels by the proper coordinated operation of the associated selecting and holding magnets. Such a multiple strapping arrangement (known as "banjo" strapping) across the wiring side of the 10 vertical units of an entire 100 point crossbar switch, provides for a 10 to 10 ratio of paths between vertical units and horizontals.

A 200 point crossbar switch (Fig. 59E) consists of 20 vertical units which may be given common access to any one of 10 levels if the levels are strapped common to all verticals. The 20 vertical units in a 200 point crossbar switch may be numbered either 0 to 19 or else 0 to 9 Left and 0 to 9 Right. Horizontal levels are numbered 0 to 9 from the bottom to the top of all crossbar switches. With the arrangement of (Fig. 59E) a 20 to 10 ratio of paths from verticals to horizontals is provided and a 10 to 20 ratio of paths is also available for traffic in the reverse direction.

The multiple field of any crossbar switch may also be divided (split) into two or more sections by omitting or cutting the strap wires between any two vertical units, resulting in what is called a "split" switch. A 200 point crossbar switch with the horizontal multiple split between the tenth and eleventh vertical units is shown in (Fig. 59F). This arrangement provides two equal multiple field sections, each section of the switch having a ten to ten ratio of paths between verticals and horizontals.

While the circuit conventions of (Fig. 59) are sufficient for block diagrams, a more detailed representation is desirable for use on schematic drawings. (Fig. 60) represents schematically one vertical unit with ten sets of leads T, R, S, wired to levels 0 to 9 and capable of connection to leads T, R, S, wired to the vertical unit. Levels 0 to 9 are shown with the associated select magnets, and the hold magnet for the particular vertical unit.

Circuits may be connected to either the vertical or the horizontal multiple of a crossbar switch depending upon the advantages of one over the other from traffic, circuit, or equipment points of view. Regardless of the choice, the number of simultaneous paths through any individual switch is limited to 10, or to 20 in the case of a split switch. To further increase the call handling capacity and to provide a most efficient switching network, the crossbar systems use two sets of switches in a series arrangement in each of the major link frames.

The series arrangement of the two sets of switches employed on line link frames is illustrated in (Fig. 61). The pattern of connection, or "spread", is "horizontal to horizontal," that is, from line (L) switch horizontals on the right to junctor (J) switch horizontals on the left. Horizontals 0 to 9 on line switch zero are connected to the zero levels of junctor switches 0 to 9; horizontals 0 to 9 on line switch one are connected to the one horizontals on junctor switches 0 to 9; repeating up to horizontals 0 to 9 on line switch nine connected to the nine horizontals on junctor switches 0 to 9. Thus it may be seen that with such a line spread, a sub-

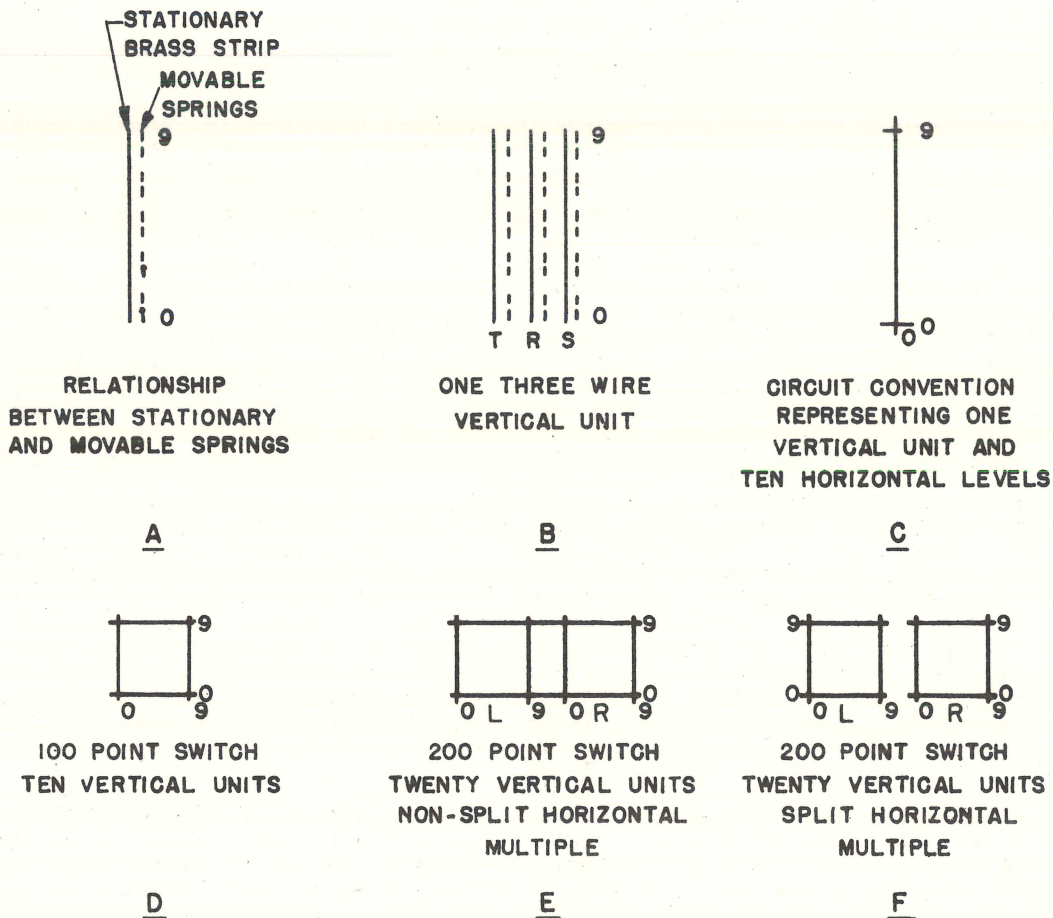

Fig. 59 - Crossbar Switch Circuit Conventions

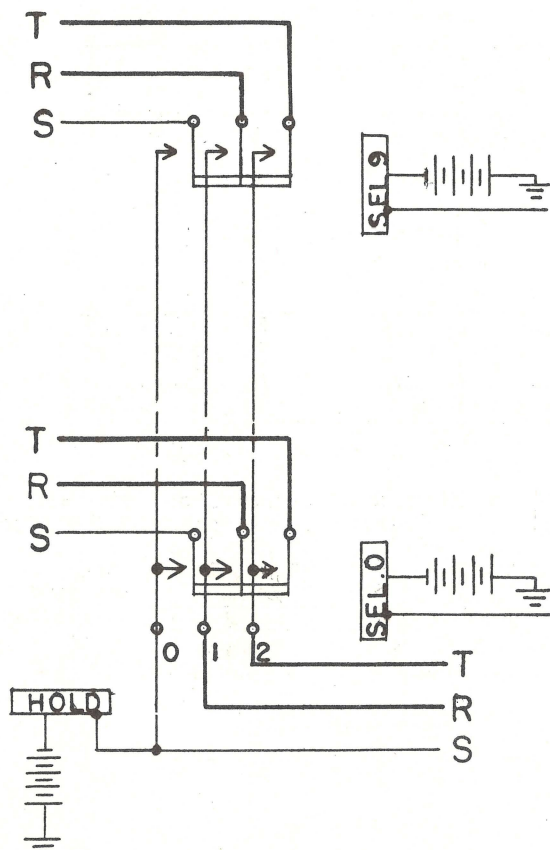

Fig. 60  
Crossbar Switch Schematic Conventions

tern of spread not only provides each junctor with access to every one of 160 trunk appearances but also each trunk appearance with access to every one of 200 juncctors. It will be noted that the horizontal multiple of the junctor switches has been split to accommodate the 200 juncctors. Access in both directions between junctor and trunk appearances is again required as in the line link frame of the previous paragraph, since the same link and junctor circuits handle both outgoing and incoming trunk traffic.

The method of connecting 160 trunk appearances to 10 trunk switches of a trunk link frame illustrated in (Fig. 63) provides a means of increasing past 100 the number of trunk appearances served by the 200 link circuits of a trunk link frame without adding more switches and without sacrificing link access to trunks as would be the case if the trunk switches were split. A full 20 links have access to each trunk appearance with this arrangement whereas, with a split switch, only 10 links would have access to each trunk appearance. The method consists of connecting two three-wire trunk circuits to each six-wire horizontal 2 to 9 and then using horizontals 0 and 1 to select or discriminate between the two trunk appearances of one level. Two crosspoints per vertical unit must now be operated to form a complete connection from the link circuit on the vertical unit to a trunk appearance on a horizontal. One crosspoint will be established at a level 2 to 9 where the desired trunk appearance and its mate will be connected through the crosspoint to the vertical unit, and the other crosspoint will be at level 0 or 1 according to which trunk appearance of the pair is the desired one. Under Method of Operation, (Chapter 6) these two mechanical crosspoints will be considered as one crosspoint, since they form one complete path from a vertical unit to a horizontal circuit. When discriminating level 0 must be used to reach the desired trunk appearance it is known as an "A" appearance and when discriminating level 1 is used it is a "B" appearance. Each trunk link frame will therefore accommodate 80 "A" appearances and 80 "B" appearances for the total of 160 trunk appearances, 16 in each trunk switch.

subscriber line connected to a vertical unit in any of the line switches will have access over one link connection to each of 10 junctor switches which, in turn, afford access to 100 junctor circuits connected to the 100 junctor switch vertical units. The series arrangement of line and junctor switches has, in this case, not only provided each subscriber line with access to every one of 100 juncctors but also has provided each junctor with access to every subscriber line on that line link frame. Access in both directions is required in the Number 5 Crossbar System since the same links and juncctors are used for both outgoing and incoming subscriber line traffic.

The series arrangement of the two sets of switches on a trunk link frame utilizes trunk (T) switches on the right and junctor (J) switches on the left interconnected by a vertical to vertical pattern of link spread (Fig. 62). Verticals 0 to 9 left of junctor switch zero are connected to verticals zero left of trunk switches 0 to 9: Verticals 0 to 9 left of junctor switch one are connected to verticals one left of trunk switches 0 to 9; and so forth up to verticals 0 to 9 left on junctor switch nine connected to verticals nine left of trunk switches 0 to 9. Similarly, verticals 0 to 9 right on junctor switch zero are connected to verticals zero right on trunk switches 0 to 9 and so forth up to verticals 0 to 9 right on junctor switch 9 connected to verticals nine right on trunk switches 0 to 9. A junctor appearing on a horizontal of any junctor switch has access over one link connection to each of 10 trunk switches which in turn provide access in a manner described in the following paragraph to 160 trunk appearances on the horizontals. Thus, this pat-

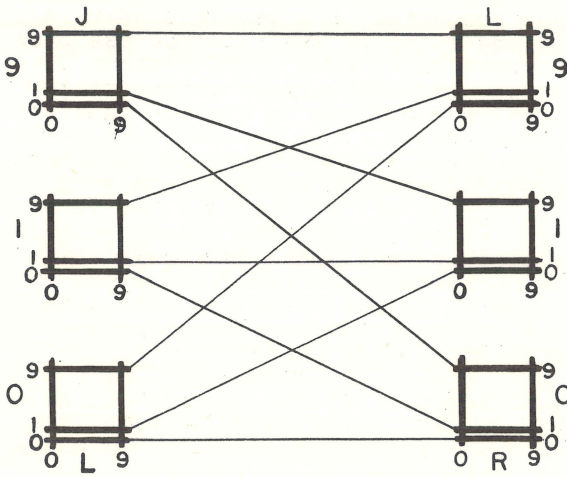

Fig. 61 - Pattern of Connection Between Switches of Crossbar No.5 Line Link Frame

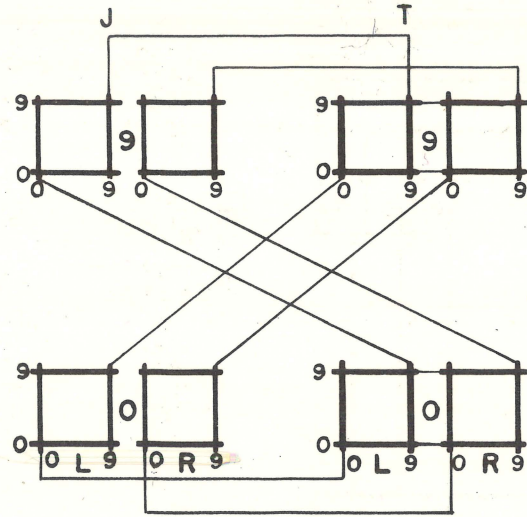

Fig. 62 - Pattern of Connection Between Switches of Crossbar No.5 Trunk Link Frame

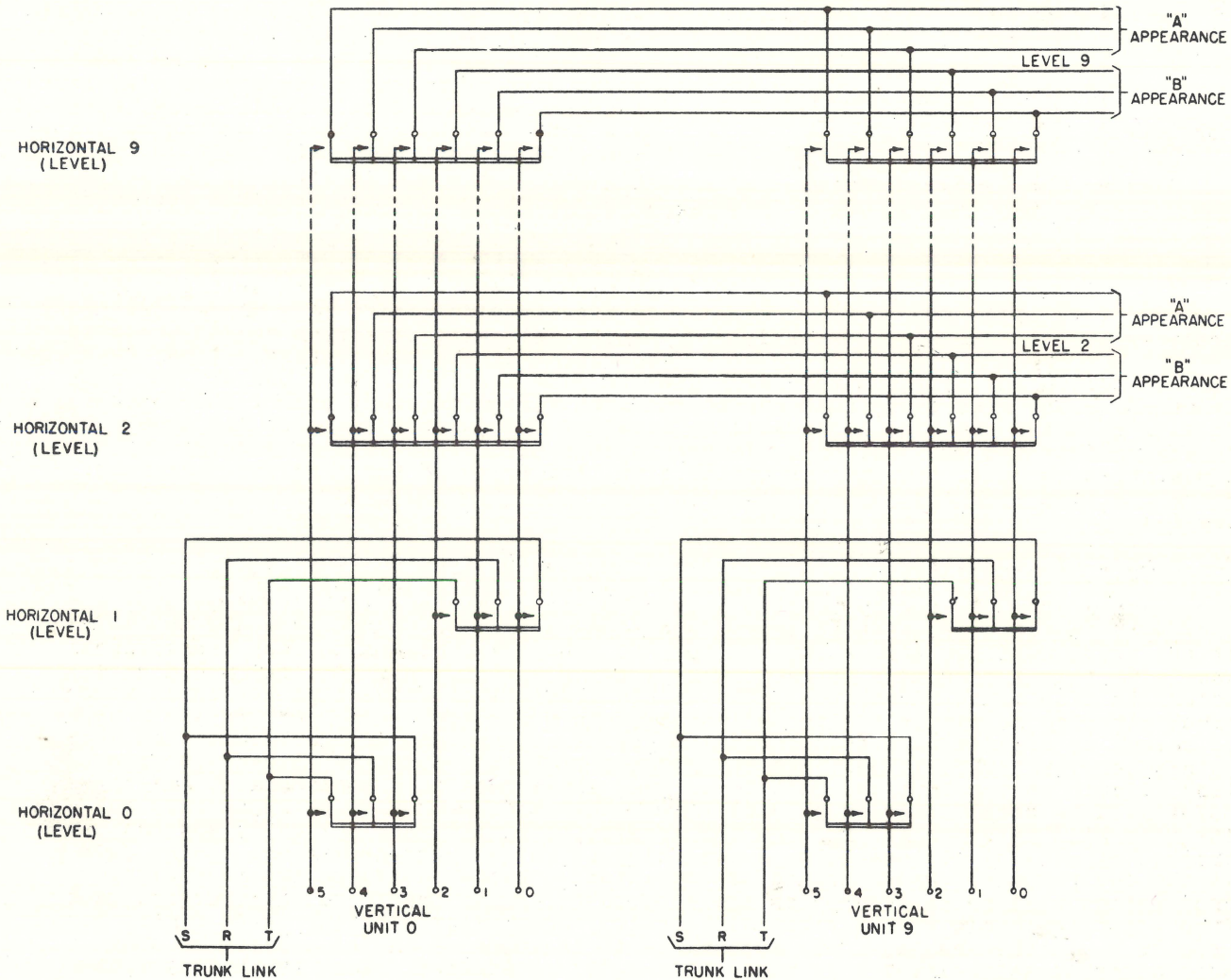

Fig. 63 - Crossbar Switch Arranged for Sixteen Trunk Appearances

Consideration of the line link and trunk link spreads shown in (Figs. 61 & 62) will reveal that a system using these two frames will have the following overall characteristics: 160 trunk appearances, 200 links, and 200 junctors per trunk link frame, with 100 junctors and 100 links per line link frame (Fig. 64). These characteristics provide a fixed call handling ability for the frames and allowances for the difference in calling rates between various subscribers must be made by varying the number of subscriber lines loaded upon each line link frame. The basic line link frame will accommodate a maximum of 290 subscriber lines (Fig. 65) this total being made up of 10 lines in each of the 10 combined line and junctor switches plus 19 lines in each of the 10 line switches. The 20th vertical in each of the 10 line switches is reserved for "no test" use and so is not available for use with a subscriber line. The 290 lines of the basic line link frame will furnish sufficient traffic to load 100 junctors if the calling rate of those subscribers is the normal heavy rate for the areas served by the Number 5 system. When the lines of an area present heavier traffic, the full 290 verticals are equipped on each basic frame but some verticals are either left idle or used with miscellaneous trunks such as toll or tandem completing trunks as described later. When the lines of an area present less average traffic it becomes necessary to add to each basic line link frame one or more supplementary bays of line switches sufficient to add the lines necessary to fully load 100 junctors (Fig. 66). The 10 horizontal circuits of each line switch in the added supplementary bay are multiplied straight across to the corresponding horizontals of the 10 line switches in the basic unit. The horizontal circuits of the ten line switches in additional supplementary bays are similarly multiplied straight across to the adjacent previous bays. Supplementary frames are furnished in sizes of 100 lines and 200 lines and through their use the 290 line capacity of a basic frame may be increased to 390, 490, 590 or 690 (Fig. 67). The effect of multiplying the supplementary bay lines switch

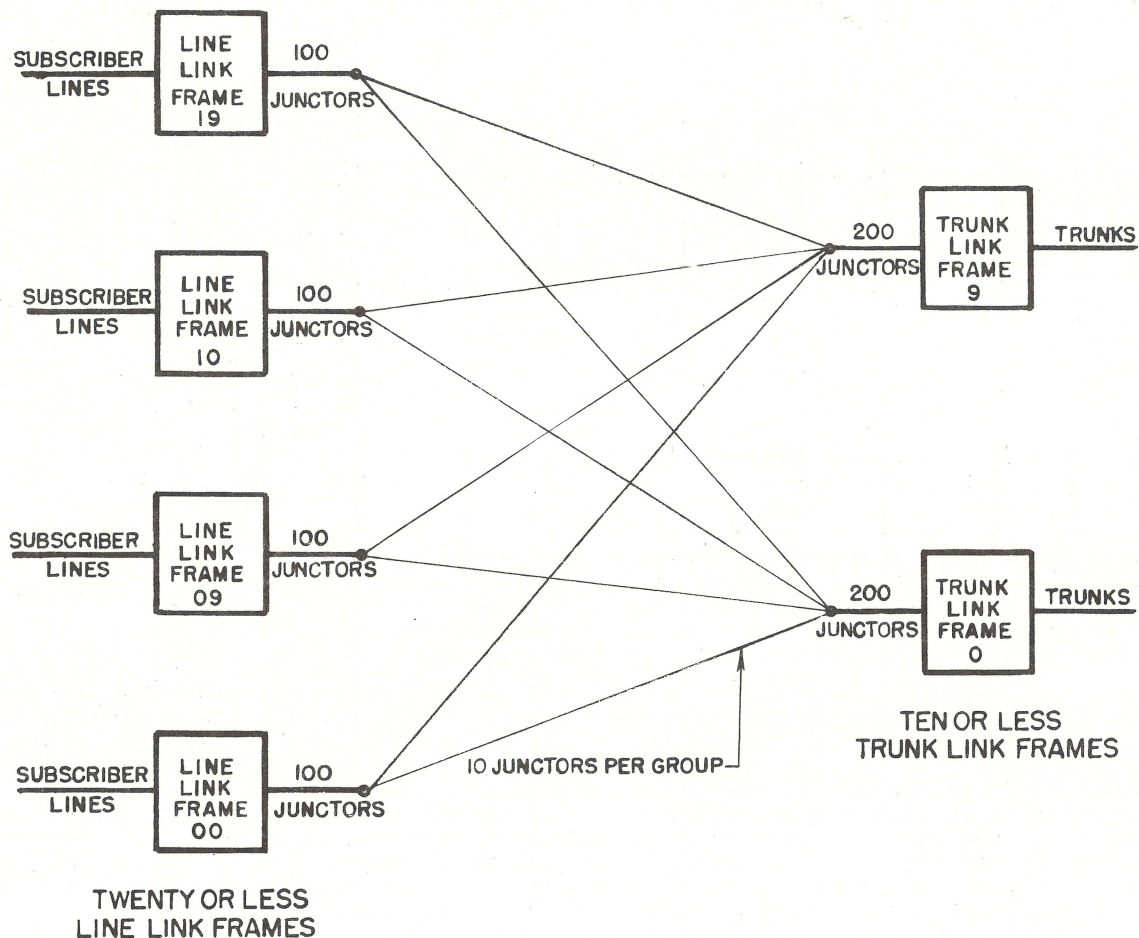

Fig. 64 - Complete Crossbar No. 5 System for Maximum 20 Line Link Frames or 10 Trunk Link Frames

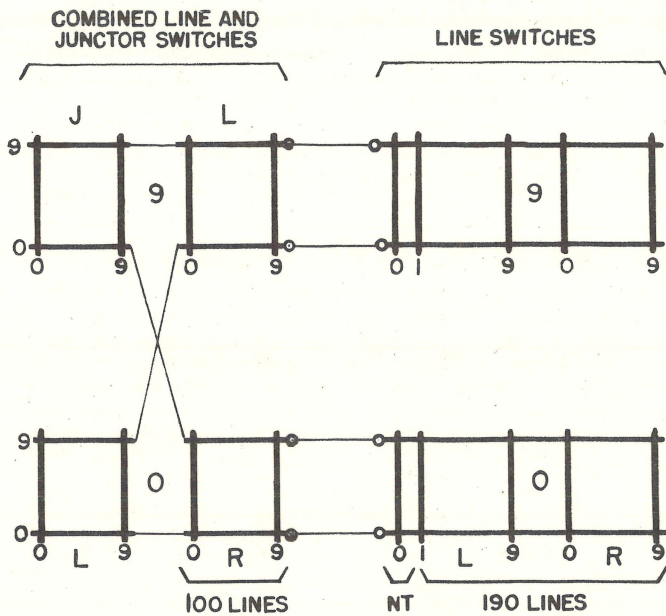

Fig. 65 - Basic Line Link Frame Accommodating 290 Subscriber Lines

horizontal switch horizontal circuits over to the basic frame line switch horizontal circuits is to increase the number of subscriber lines which have access to the same 10 horizontal circuits of any line switch. The line switch half of the combined line and junctor switch is included in this multiplying of the horizontal circuits and is considered as part of the 10 line switches of the basic unit. A "horizontal group" of lines are those which have common access to the same 10 line switch horizontal circuits and varies in size between a minimum of 29 heavy calling rate lines (basic unit with no supplementary bay) and a maximum of 69 light calling rate lines (supplementary bays added).

Inter-connection of line link and trunk link frames into a unified arrangement capable of control by a group of common control circuits, or markers, and capable of meeting the necessary switching requirements, is illustrated in (Fig. 64). The requirements of such a system may be simply stated as follows: (1) each subscriber line must have access to every outgoing trunk in that office, and (2) each subscriber line must have a minimum of 10 paths through the switching equipment to each outgoing trunk. The requirement (1) above results from the Bell System Policy of providing each subscriber with a possible connection to every other subscriber no matter where located. Requirement (2) above is a practical working compromise between the two limits of providing insufficient circuits, thereby effecting economy in equipment, and providing more than sufficient circuits, thereby insuring call paths available even during periods of peak over-load. The conflicting factors of call path availability and equipment economy are both more nearly satisfied when 10 paths through the switching equipment are available to each call. The call path

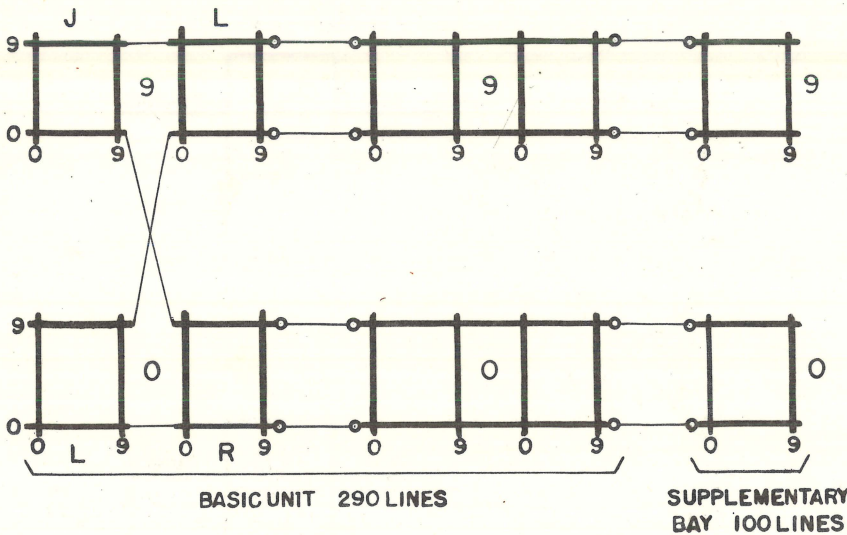

Fig. 66 - Supplementary Bay Increasing Line Capacity of Basic Unit

between line link and trunk link frames is carried over junctor circuits and since each trunk link frame will accommodate 20 such junctors, requirements (1) and (2) can only be met by a maximum of 20 line link frames each having 10 junctors into a particular trunk link frame (Fig. 64). Also, requirements (1) and (2) can only be met by a maximum of 10 trunk link frames each having 10 paths from a particular line link frame whose junctor capacity is 100. Thus it may be seen that unless some multiplying of junctors is done, such as with extension trunk link frames, the limit of a crossbar number 5 installation is 20 line link frames and 10 trunk link frames.

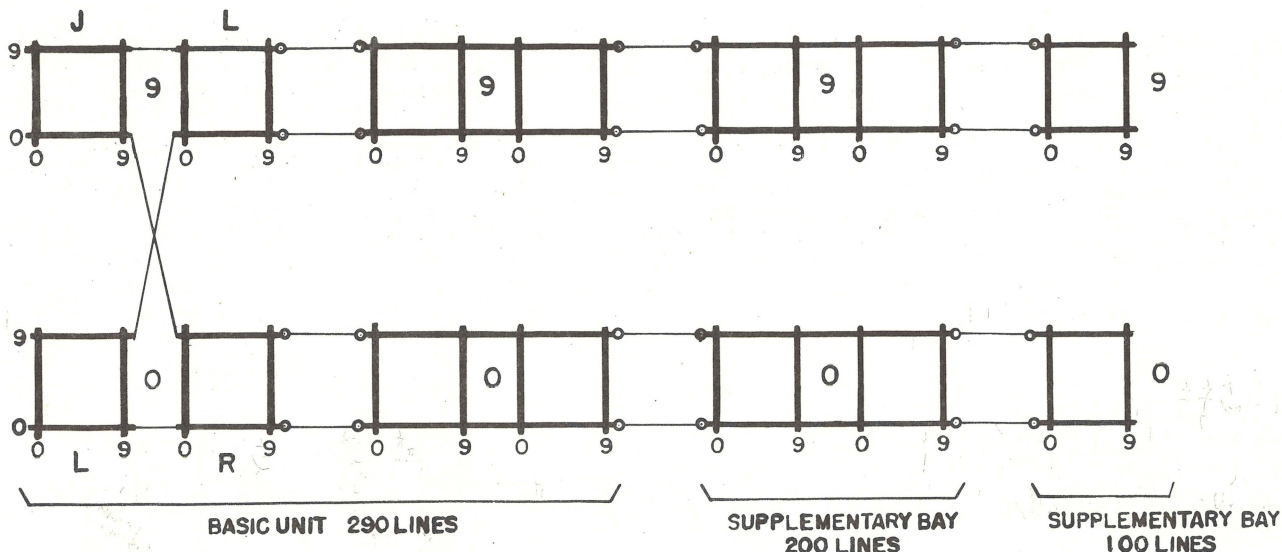

Fig. 67 - Capacity of Basic Unit Increased to Maximum 590 Subscriber Lines

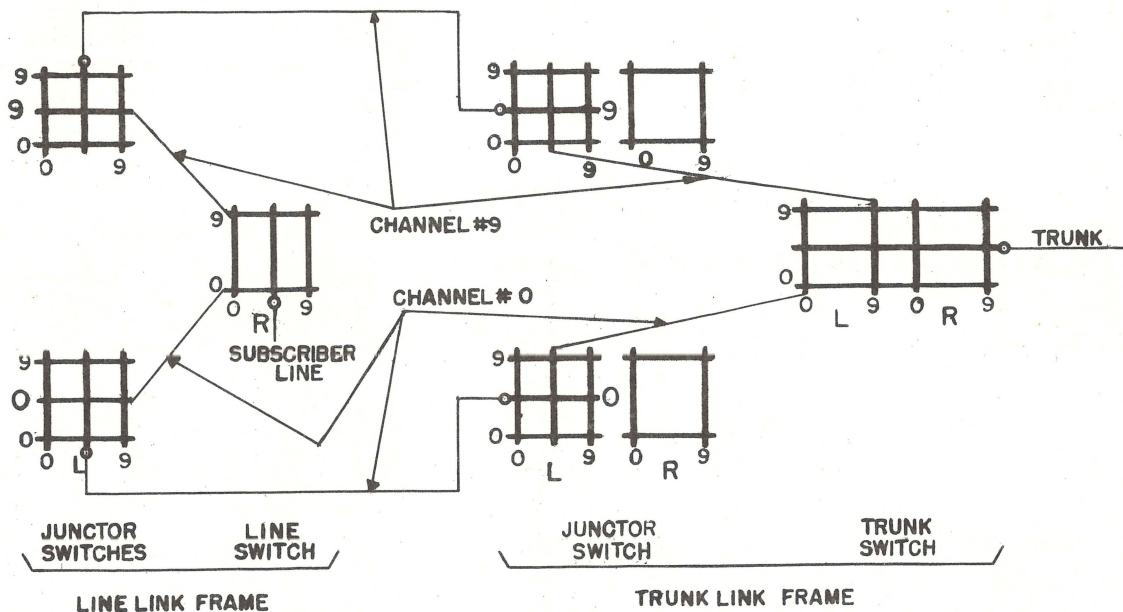

Fig. 68 - Ten Channels Between Each Subscriber Line and Each Trunk

A complete path (channel) between a subscriber line and a trunk or register will include a line link circuit, a junctor circuit, and a trunk link circuit as illustrated in (Fig. 68). The method of connecting the required 10 minimum channels to the junctor switches of one line link and one trunk link frame is also illustrated. Here may be seen how each subscriber line has one channel through each of ten junctor switches to every outgoing trunk. These same 10 channels are available for use when the trunk is an incoming trunk desiring access to a called subscriber line.

When job conditions, such as a light to medium subscriber line calling rate, require the furnishing of more than 20 line link frames, or more than 10 trunk link frames, to fully load any one marker group the plan of interconnection illustrated in (Fig. 69) is applied. This plan meets the switching requirements (1) and (2) above through increasing the junctor capacity of each trunk link frame to 400 junctors and providing each group of 400 junctors with multiple appearances on the two link frames of a pair. Increasing the junctor capacity of the trunk link frame from 200 to 400 is accomplished by adding an extension trunk link frame to each trunk link frame which then may accommodate 10 paths from each of 40 line link frames. The extension trunk link frame

contains 10 extension junctor switches which are exact duplicates of those in the regular trunk link frame and which, through multiplying of their vertical units to the verticals of the regular trunk link frame, provide access from twice as many junctors to the same number of trunk link circuits (200) in each trunk link frame. This traffic unbalance, of 400 junctors feeding 200 links, is corrected by providing the 400 junctors on each trunk link frame with a multiple appearance on another trunk link frame so that each group of 400 junctors has access to 400 trunk link circuits on a pair of trunk link frames. Thus a second maximum size job is seen to result from the addition of extension trunk link frames and consists of 40 line link frames and 20 trunk link frames with extensions.

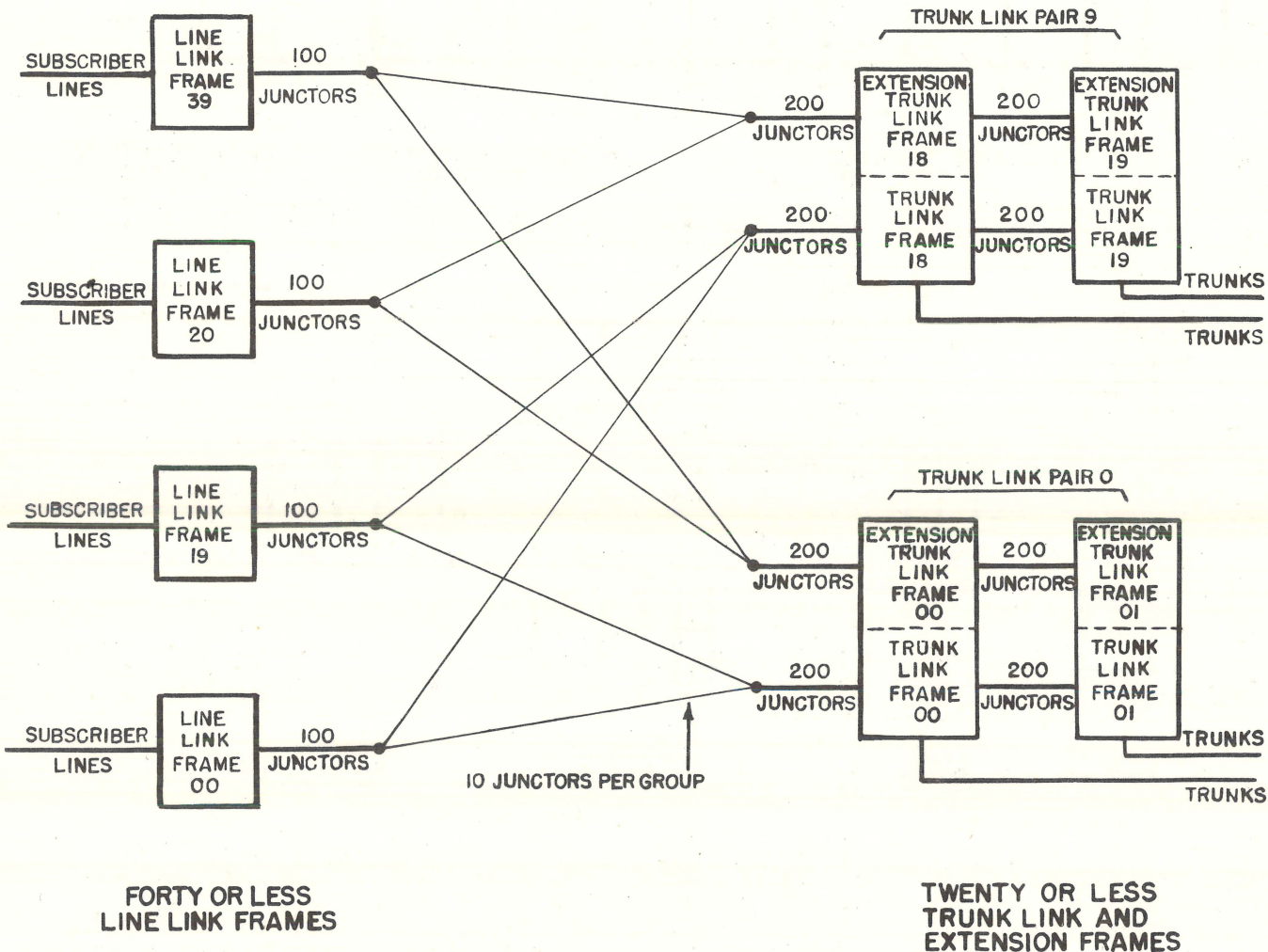

Fig. 69 - Complete Crossbar No. 5 System for 40 Line Link Frames and 20 Trunk Link Frames

### Section 3. Circuit Features

The Marker Circuit is the heart of the crossbar dial system and provides control for establishing connections through a dial central office by an arrangement which may be described as "indirect control" since the circuit network used for establishing connection through the various units of equipment is separate and distinct from the talking and signalling circuits. One type of marker controls traffic both outgoing from, and incoming to, line link frames which may be recognized as a departure from the practice in the Number 1 crossbar system, where two types, the originating and terminating markers were used. The purpose of the marker is to test and select idle paths or channels between the lines and trunks appearing respectively on line link and trunk link frames. In the performance of its 5 kinds of jobs the marker performs several other functions before that of channel selection depending upon the type of job, ie; (1) the Dial Tone Job requires that the marker test and locate an idle originating register before proceeding with channel closure to the given calling line. (2) The Outgoing Trunk Job requires that the marker test and seize a trunk to the called office, and when necessary associate that trunk with an outgoing sender, before closing a channel to the given calling line. (3) The Incoming Trunk Job requires that the marker locate the line link equipment associated with the called telephone number before closing a channel between it and the given incoming trunk. (4) The Intra-office and Reverting Trunk Job requires that the marker, upon recognizing the called office as being the one it serves, perform the functions of both job 2 and 3 above and further, that the marker recognize when the calling and called parties are on the same line for selection of a reverting trunk. (5) The Completing Trunk Job (toll or tandem) requires that the marker recognize an incoming call as being for some distant office, that it then locate the line link apparatus associated with the incoming trunk as in job 3 and that it test and seize a trunk to the distant office as in job 2 before closing a channel between the incoming and outgoing trunks. These 5 jobs when performed by the marker all result in the closure of a channel and differ from each other only in that sometimes the marker is given the line and expected to find an idle trunk and sometimes it is given a trunk and expected to find the line. The markers are in command of and control the major switching functions, and serve as the directing mechanism in the system, until the desired connection has been established.

The Outgoing Sender Circuit is the mechanism which electrically transmits the called telephone number to a distant office in one of 4 pulsing methods. Outgoing senders are of 4 types named according to the method of outpulsing as follows: Dial pulse, multi-frequency, revertive pulse and call indicator outgoing senders. These 4 senders are used for calls to subscribers in step-by-step, crossbar, panel, and manual offices respectively.

The Register Circuit is the mechanism employed to receive and store electrical impulses which represent the called telephone number. Register circuits are of two types: The Originating Register which receives the called number from the impulses of a calling subscriber dial, and the Incoming Register which receives the called number from an originating office in one of 4 pulsing methods. The 4 types of incoming register are named for these methods as follows: multi-frequency, revertive pulse, dial pulse, and central B incoming registers which complete calls from crossbar, panel, step-by-step, and manual offices respectively.

The Trunk Circuit is the mechanism employed to convey the talking and signaling paths between the trunk link frames of the originating and terminating offices in a call. In the case of two subscribers in the same Number 5 office calling each other the mechanism is contained in one circuit called an Intra-Office Trunk while in the case of a call between subscribers in two different offices the mechanism is divided into an outgoing trunk circuit in the originating office and an incoming trunk circuit located in the terminating office connected together by a pair of wires between the two offices. The functions of the outgoing trunk circuit include furnishing talking battery and ground to the calling subscriber, holding the crosspoints of a talking channel through trunk link and line link frames while the calling subscriber handset is off the hook, accepting a called party answer signal from the incoming trunk circuit, acknowledging this called party answer condition by causing the calling party to be charged for the message, detecting the replacing of the calling handset on its hook, and recognizing this disconnection by releasing the channel crosspoints in the originating office and the incoming trunk circuit in the terminating office. The functions of the incoming trunk circuit include holding the channel crosspoints through trunk link and line link frames of the terminating office, ringing the called subscriber bell, detecting the removal of the called party handset from its switch hook, recognizing this called party answer condition by discontinuing ringing and by furnishing talking battery and ground to the called party while relaying an answer signal to the outgoing trunk, detecting the replacing of the called party's handset on its switch hook, and acknowledging this disconnect condition by relaying it to the outgoing trunk circuit.

## CHAPTER VI

METHOD OF OPERATIONSection 1. The Intra-Office Call.

A call between two subscribers in the same office but not on the same line and who are served by the same marker group is known as an Intra-Office Call and the frames involved in completing this type of call are shown in Figs. 70 and 71. In order that the reader may continuously have before him the names of all frames used, it is suggested that these pages be left open while reading the following text.

A calling subscriber originates a call by lifting his handset (Fig. 70) completing a path from his subset to the line link frame upon which his line is located. Part of his line circuit consists of a vertical unit of a crossbar switch on the "line switch" portion of the line link frame. (Chapter IV, Sec.2). The calling line link frame seizes and connects to an idle marker through the line link marker connector frame (Chapter IV, Sec.20). Certain information to be used later by the marker in again locating the calling line link frame and line is given to the marker. The marker recognizes the call as being from a line link frame, and it therefore proceeds thru the trunk frame test lead connector (TFTLC) frame to examine all trunk link frames for idle originating registers. An idle trunk link frame with idle originating registers will be selected. The marker seizes the selected trunk link frame through its trunk link connector frame (Chapter IV, Sec.21) and then, while selecting an idle originating register, proceeds to also seize the calling line link frame through the line link connector frame (Chapter IV, Sec.22). Complete information about the calling line's location in the line link frame and its class of service is now passed from the line link frame to the marker, from where it is passed on to the originating register (Chapter IV, Sec. 6). The marker selects the combination of circuits (dialing channel) through the calling line link frame and trunk link frame to be used. The connection from the calling subscriber to the originating register is closed through the 4 crosspoints of the dialing channel by the marker operating the associated selecting and holding magnets. The originating register returns dial tone to the subscriber. In addition to the line link location and class of service information already stored in the originating register the marker now supplies the number of the line link circuit used in the dialing channel to the originating register. The marker and the 3 connector circuits release. Control of the 4 holding magnets of the dialing channel was assumed by the originating register previous to the release of the marker and is retained by the register under control of the lifted calling subscriber handset. The select magnets for this dialing channel released with the marker, freeing them and the associated frames for use in the establishing of additional dialing or talking channels. The circuit functional steps thus far performed from the removal of the calling party's handset to the receiving of dial tone are automatically performed in a pre-determined sequence whenever a handset is lifted to originate a call. They constitute one of the 5 jobs performed by markers and are known as the Dial Tone Job.

The calling subscriber receives dial tone from the originating register, and proceeds to dial the digits of the called telephone number. The originating register stores these digits in their dialed sequence, and is capable of accepting from 4 to 11 digits for any one call. The originating register (turn to Fig. 71) connects to an idle marker through the originating register marker connector frame (Chapter IV, Sec.18) and transfers the following information to the marker: the calling line location and its class of service, the number of the line link circuit used in the dialing channel, and the called telephone number. The marker now in use may or may not be the same one previously used on this call to establish the dialing channel. The marker recognizes the dialed office code as being associated with its own group of line link frames, and it therefore proceeds thru the trunk frame test lead connector (TFTLC) frame to examine all trunk link frames for idle intra-office trunks. An idle trunk link frame with idle intra-office trunks will be selected. The marker seizes the selected trunk link frame and connects to it through its trunk link connector frame. The marker then selects an idle intra-office trunk. While selection of an intra-office trunk is proceeding the marker, through the number group connector frame, seizes the number group frame upon which the called line location information appears as a set of cross-connecting jumpers. The number group frame gives the marker the following information regarding the called line; the line link frame number, the called line location on that frame, and the ringing current to be applied. The number group and number group connector frames are released. The marker seizes the line link frame containing the called line through the line link connector frame. The called line is tested for a busy condition, and if found idle the marker proceeds to select and close an idle terminating channel from the intra-office trunk to the called line. Simultaneously, the

marker connects the intra-office trunk to the proper ringing voltage at the ringing selection switch. This voltage proceeds no further than the trunk circuit at this time, and is ready for application to the called subscriber line and ringers. If the called line were busy, the marker would release the intra-office trunk and select an idle busy tone trunk, then proceed with the following circuit action the same as for an idle line. No terminating channel would exist on a busy tone call. Let us assume an idle line and the marker, having established the terminating channel to the called party from the intra-office trunk, seizes the calling line link frame through the line link connector frame, then tests and selects an originating channel from the calling line to the intra-office trunk. The dialing channel and the originating register are released, allowing the marker to close through the 4 crosspoints of the originating channel by operating the associated selecting and holding magnets. Control of the 4 holding magnets of the terminating channel and of the 4 holding magnets of the originating channel is assumed by the intra-office trunk after which the marker and its associated connectors release. The terminating and originating channel selecting magnets release, freeing them and the frames upon which they appear for use in establishing other channels. Ringing is now applied to the called line through the intra-office trunk, over the terminating channel from the ringing selection switch, and will be stopped upon removal of the called subscriber handset. Talking battery and ground will be furnished to the calling and called parties by the intra-office trunk and release of all channel crosspoints will result when the talking battery path to the calling and called parties is broken by the replacing of their handsets. The circuit functional steps performed from the time of seizure of the marker by a completely dialed originating register to the ringing of the called party's bell are automatically performed in a predetermined sequence whenever the marker is seized by an originating register containing a call for an individual idle line in the same office as the calling line, and they constitute another of the 5 jobs performed by markers, this job being known as the Intra-office Trunk Job.

### Section 2. The Reverting Call.

A call between two subscribers on the same line is known as a Reverting Call and is a special case of the Intra-office Call. The frames involved in completing this type of call are shown in (Fig. 71A). The reverting call proceeds exactly the same as the intra-office call described in Section 1 from the calling subscriber lifting his handset through the point where the number group and number group connector frames are released. At this time the marker has completed its dial tone job and is preparing for selection of the terminating channel as part of its intra-office trunk job. The marker now contains the line link location information for both the calling and the called lines and upon recognizing the exact match between the two locations it deviates from the circuit functions of the intra-office trunk job as will be described in the following paragraph.

The marker releases the previously selected intra-office trunk and associated trunk link and connector frame (Fig. 71) and now proceeds thru the trunk frame test lead connector (TFTLC) frame to re-examine all trunk link frames for idle frames containing idle reverting trunks. An idle trunk link frame with idle reverting trunk will be selected (Fig. 71A). The marker seizes the selected trunk link frame and connects to it through its trunk link connector frame. The marker selects an idle reverting trunk and then seizes the line link frame containing the called line through its line link connector frame. The busy condition of the called line is recognized as normal for the reverting call and upon release of the dialing channel, the 4 crosspoints of a reverting channel are closed through by the marker operating the associated selecting and holding magnets. Control of the reverting channel is assumed by the reverting trunk after which the marker and its associated connectors release, freeing them for use in establishing additional channels. Busy tone is transmitted to the calling subscriber by the reverting trunk and should cause him to replace his handset. Normal ringing is now applied to the called subscribers' bells and a special reverting ringing of one half second ring every 3 seconds is applied to the calling subscriber bells. Ringing will be stopped upon removal of the called subscriber handset, indicating to the calling subscriber that the call has been answered and that he should again remove his handset. Talking battery and ground will be furnished to the calling and called parties by the reverting trunk and release of all channel crosspoints will result when the talking battery path to the calling and called parties is broken by the replacing of their handsets.

### Section 3. The Outgoing Call

A call originating in a Number 5 office and terminated in some office other than the originating office is an outgoing call and may be one of two different types. An outgoing call to a subscriber requires that a sender be associated with the outgoing trunk to electrically pass the called number to the terminating office. Outgoing calls to

operators, such as 0, 211, 411, etc. do not require a sender since the called number may be passed orally to the operator. The dialed office code indicates to the marker whether or not a sender is required for a call to any particular route, and both types of outgoing call are described in the following paragraphs.

The outgoing call proceeds through the steps previously described (Chapter VI, Sec.1) as the dial tone job and, when the called number has been dialed, the originating register engages the marker through its originating register marker connector (Fig.72). The following information is transferred to the marker: The calling line location and its class of service, the number of the line link used in the dialing channel, and the called telephone number. The marker recognizes the dialed office code as being associated with a distant office and as being a route either requiring a sender or not. Let us assume a route requiring a sender and the marker therefore examines all sender groups of the proper type for idle outgoing senders. When it has determined that a sender is available, the marker proceeds thru the trunk frame test lead connector (TFTLC) frame to examine all trunk link frames for idle outgoing trunks to the called office. An idle trunk link frame and an idle outgoing trunk will be selected and seized through the trunk link connector frame. While selection of an outgoing trunk is proceeding the marker, through the outgoing sender connector frame, selects and seizes an idle outgoing sender, transferring to that sender the called telephone number. Seizure of the trunk, followed by seizure of the outgoing sender results in connecting the two together through a crosspoint on the outgoing sender link frame. Meanwhile, immediately following seizure of the trunk link frame, the marker has seized the line link frame containing the calling line through its line link connector frame. When the marker has determined that an idle channel exists between the calling line and the selected trunk it releases the 4 crosspoints of the dialing channel and operates the 4 crosspoints of the outgoing channel. The marker and associated connectors release after the outgoing channel is successfully closed and after the outgoing sender has successfully completed a continuity and polarity test of the outgoing trunk. Upon signal from the terminating end the outgoing sender will output the called telephone number on a call indicator pulse, revertive pulse, dial pulse, or multi-frequency pulse basis depending upon whether or not the call is to a manual, panel, step-by-step, or crossbar office. Upon completion of outputting the outgoing sender and outgoing sender link will be released and the outgoing trunk will be advanced to a condition where it supplies talking battery and ground to the calling subscriber and is capable of recognizing a called party receiver off-hook signal from the incoming trunk at the terminating office. Control of the outgoing channel crosspoints is assumed by the outgoing trunk and when the talking battery path to the calling party is broken by the replacing of his handset these crosspoints will be released. The outgoing channel crosspoints will also release after a timed interval when a signal is received from the terminating office that the talking battery path to the called party has been broken by the replacing of his handset.

A call for a route not requiring a sender will result in marker action the same as in the previous paragraph up to the point of the marker recognizing the route. At this point selection of a trunk will proceed omitting the selection of an outgoing sender and the associated circuit action at the outgoing sender link and outgoing sender connector frames. Upon selection and seizure the outgoing trunk will immediately advance to a condition where it supplies talking battery and ground to the calling subscriber and where it assumes control of the originating channel crosspoints. These crosspoints will be released immediately by the outgoing trunk if the calling subscriber replaces his handset any time before the operator answers. After that time the crosspoints can be released only if both the calling party and the called operator disconnect. The circuit functional steps performed from the time of seizure of the marker by a completely dialed originating register to the assuming of crosspoint control by the outgoing trunk are automatically performed in a predetermined sequence whenever the marker is seized by an originating register containing a call for a line which is not in the same office as the calling line and they constitute another of the 5 jobs performed by markers, this job being known as the Outgoing Trunk Job.

#### Section 4. The Incoming Call

A call terminating in a number 5 office after having originated in some office other than the terminating office is an Incoming Call. An incoming call requires that an incoming register be associated with the incoming trunk to electrically receive the pulses representing the called number. These pulses will be multi-frequency, revertive, or dial pulse according to whether the originating office is crossbar, panel, or step-by-step system. A manual originating office requires the services of a revertive pulse incoming register modified for central B use, and this call will be described separately in the succeeding paragraphs.

Seizure of an incoming trunk (Fig. 73) at its originating end will cause that trunk to signal the incoming register link frame upon which it appears and will result in the linking together of the trunk and an idle incoming register through a crosspoint on the incoming register link frame. Control of this crosspoint will be assumed by the incoming register. In the case of panel and crossbar, linking an incoming register to the incoming trunk causes a signal to be passed over the trunk to the outgoing sender at the originating end which responds by outputting the called telephone number. In the case of step-by-step these pulses are generated by dials instead of outgoing senders and in all cases the pulses are received and stored by the incoming register. When the pulses of the entire called telephone number have been received the incoming register connects to an idle marker through the incoming register marker connector frame (Chapter IV Sec.19) and transfers the following information to the marker: The called telephone number and office or station identifying digit if any, and the trunk link frame number upon which the incoming trunk appears. The marker seizes the indicated trunk link frame and connects to it through its trunk link connector frame and then proceeds, through the number group connector frame, to seize the number group frame upon which the called line location information appears. The number group frame gives to the marker the following information regarding the called line: The line link frame number, the called line location on that frame, and the ringing current to be applied. The number group and number group connector frames are released. The marker seizes the line link frame containing the called line through the line link connector frame. The called line is tested for a busy condition and if found idle the marker proceeds to select and close an idle incoming channel from the incoming trunk to the called line. Simultaneously the marker connects the incoming trunk to the proper ringing voltage at the ringing selection switch. This voltage proceeds no further than the incoming trunk circuit at this time and is ready for application to the called subscriber line and ringer upon the successful operation by the marker of the 4 crosspoints in the incoming channel. Control of the 4 holding magnets of the incoming channel is assumed by the incoming trunk after which the marker and its associated connectors release as do the incoming register and the incoming register link. The incoming channel selecting magnets release, freeing them and the frames upon which they appear for use in establishing additional channels, and the ringing is now applied to the called line through the incoming trunk and incoming channel from the ringing selection switch. Ringing will be stopped upon removal of the called subscriber handset by breaking the connection from the incoming trunk to the ringing selection switch. Talking battery and ground will be furnished to the called party by the incoming trunk and a called party receiver-off-hook signal will be returned to the outgoing trunk circuit in the originating office. Release of the 4 incoming channel crosspoints will occur upon signal from the originating office that the talking battery path to the calling party is broken by the replacing of his handset and a timed release may occur prior to the calling party disconnect when the talking battery path to the called party is broken by the replacing of his handset. The circuit functional steps performed from the time of seizure of the marker by a completely pulsed incoming register to the ringing of the called party's bell are automatically performed in a predetermined sequence whenever the marker is seized by an incoming register containing a call for an individual idle line and they constitute another of the 5 jobs performed by markers, this job being known as the Incoming Trunk Job.

An incoming call from a manual office will proceed through the same circuit functional steps as described in the previous paragraph with the exceptions to be described. Seizure of the incoming trunk will result in the linking of that trunk to an idle revertive pulse incoming register modified for central B service. This central B incoming register is divided into two portions interconnected by 4 wires (Fig. 73A). The two portions consist of the incoming register proper, located in the number 5 office, and a central B switchboard sender located in the office with the dial system B (DSB) switchboard. The switchboard may or may not be located in the same number 5 office. Linking together of the incoming trunk and central B incoming register passes a signal along to the central B switchboard sender which in turn associates itself with an idle position in the DSB switchboard. The DSB position applies one, two or three spurts of tone to the talking path now existing between the DSB operator and the manual office operator. The tone signals the manual office operator to speak the digits of the called number and also signals the DSB operator to listen for that number. The DSB operator presses numerical keys in her position corresponding to the called number and the central B switchboard sender records this number and releases the DSB position for use in other calls. The central B switchboard sender relays the called telephone number to the central B incoming register by means of revertive pulsing and, with the called number completely stored in the incoming register the call can proceed as previously described from the point of the incoming register connecting to an idle marker through the incoming register marker connector frame.

Section 5. The Tandem or Toll Completing Call

A call which enters a number 5 office on an incoming trunk and leaves that number 5 office on an outgoing trunk, neither originating nor terminating in the number 5 office, is a completing call to that office. Completing type service may be given to calls requiring toll and tandem type of switching by a number 5 office in addition to its serving the subscribers in its own local area. Since both incoming calls and completing calls arrive at a number 5 office over an incoming trunk it is in many cases economical to provide dual-purpose incoming trunks for toll and tandem call switching which are called incoming trunks arranged for completing. Calls incoming to a number 5 office on this type of trunk may be both incoming, for termination in the number 5 office, and completing, for termination in other offices reached over outgoing trunks from the number 5 office. Completing type calls may be handled by a number 5 office either mechanically, when the called office and telephone number arrive as pulses, or manually, when the called office and telephone number are transmitted orally between an operator at the calling source and an operator in the number 5 office. In the latter case pulsing of the incoming register will be done by the operator in the number 5 office, and in the former case the pulsing will originate in the sender circuit of a crossbar or panel office, or in the dial circuit of a step-by-step subscriber or dial equipped (A) board.

The completing call proceeds through the steps previously described (Chapter VI Sec.4) as the incoming trunk job up to the point of seizing an idle marker, after which time the call proceeds through the steps described (Chapter 6 Sec. 3) as the outgoing trunk job starting at the point of marker seizure. Seizure at its originating end of an incoming trunk arranged for completing (Fig. 74) will cause that trunk to signal the incoming register link frame upon which it appears and will result in the linking together of the trunk and an idle incoming register through a crosspoint on the incoming register link frame. Control of this crosspoint will be assumed by the incoming register and its closure causes a signal to be passed over the trunk to the outgoing sender at the originating end which responds by outpulsing the called office and telephone number. When pulsing is complete the incoming register engages an idle marker through its incoming register marker connector. The following information is transferred to the marker: The incoming trunk identifying number and its type (toll or tandem completing), and the called office and telephone number. The marker recognizes the called office code as being associated with a distant office and as being a route either requiring a sender or not. Let us assume a route requiring a sender and the marker therefore examines all sender groups of the proper type for idle outgoing senders. When it has determined that a sender is available, the marker examines all trunk link frames for idle outgoing trunks to the called office. An idle trunk link frame and idle outgoing trunk will be selected and seized through the trunk link connector frame. While selection of an outgoing trunk is proceeding the marker, through the outgoing sender connector frame, selects and seizes an idle outgoing sender and transfers to that sender the called number. Seizure of the trunk, followed by seizure of the outgoing sender results in the marker connecting the two together through a crosspoint on the outgoing sender link frame. Meanwhile, immediately following the seizure of the trunk link frame, the marker guided by the trunk identifying number previously received, seizes the trunk number group frame containing information regarding the location of the line link appearance of this completing trunk. Each completing type trunk is provided with a line link appearance in addition to its trunk link appearance, the former being used only for completing calls and the latter only for incoming calls. The trunk number group frame gives the marker the following information regarding the incoming trunk; the line link frame number and the location of the vertical unit assigned to the completing trunk. The trunk number group and number group connector frames are released. The marker seizes the line link frame containing the completing trunk through the line link connector frame. When the marker has determined that an idle channel exists between the completing trunk and the outgoing trunk it operates the 4 crosspoints of the outgoing channel. The marker and associated connectors release after the outgoing channel is successfully closed and after the outgoing sender has successfully completed a continuity and polarity test of the outgoing trunk. The incoming register and incoming register link are also released. Upon signal from the terminating end the outgoing sender will outpulse the called number as call indicator, revertive, dial, or multi-frequency pulses depending upon whether the call is terminating in a manual, panel, step-by-step or crossbar office. Upon completion of outpulsing the outgoing sender and outgoing sender link release and the outgoing trunk advances to a condition capable of recognizing a called party receiver-off-hook signal from the terminating end and relaying that signal to the originating office. Control of the outgoing channel crosspoints is assumed by the outgoing trunk and their release will occur upon signal from the originating office. The circuit functional steps performed by the marker from the time of its seizure by a completely pulsed incoming register to the time of release after closure of the outgoing

channel are automatically performed in a predetermined sequence whenever the marker is seized by an incoming register containing a call from a trunk arranged for completing for an office other than the number 5, and they constitute another of the 5 jobs performed by markers, this job being known as the Toll or Tandem Completing Job.

#### Section 6. The Inter-Marker Group Call

A call originating in one number 5 office and either terminating or completing in another number 5 office both offices being located in the same building and served by a different group of markers is an Inter-Marker Group Call. This call may be recognized as a special case of an outgoing call and an incoming or completing call within the same building and advantage is taken of this nearness by providing circuits inter-connected to both marker groups over cable lengths which would otherwise be extremely uneconomical for the number of leads involved. The circuits provided, known as inter-marker group senders, serve the dual purpose of outgoing senders in the originating office marker group and incoming registers in the terminating or completing office marker group and replace these circuits in the inter-marker group call. Thus, a marker seized by an originating register containing an inter-marker group call will perform its regular outgoing trunk job for a call requiring a sender. It will, however, be forced to attach an inter-marker group sender to the trunk instead of an outgoing sender since the trunk seized can only have access to that type of sender. The inter-marker group sender will accept from the outgoing office marker the information normally given an outgoing sender. Upon release of the outgoing office marker the inter-marker group sender will seize a marker in the terminating or completing office through an incoming register marker connector frame. From this point on, the inter-marker group sender functions as an incoming register while the marker performs the circuit functions of its incoming trunk or toll-tandem completing trunk job.

#### Section 7. Message Charging

Subscribers served by a number 5 office may be charged for their messages on the basis of a flat rate, message register, coin, or automatic message accounting (AMA) class of service. Flat rate subscribers are billed a fixed amount each billing period without regard to the number of local calls they have made plus a variable amount depending upon the number and length of their calls to other charge zones and toll points. Flat rate subscribers, when making calls to zone and toll points, must dial an operator (zero, 211, etc.) who will time their call and will record the time and charges for later billing. Message rate subscribers are billed one charge unit for each message unit recorded on the message register (Chapter 3 Sec. 9) located in the number 5 central office and associated with the telephone number. A charge unit may be 5 or more cents depending upon the local rate up to a minimum guaranteed number of calls, and a lesser amount for succeeding calls. Calls to local charge points may be dialed direct by the message rate subscriber and the message register will automatically record one message unit per initial charge period plus one message unit per overtime charge period. However, the services of an operator for timing and charging are still required on calls to zone and toll charge points due to the variation in rate to the various points. Coin subscribers are charged for their local calls by requiring the deposit of a coin (five or ten cents) for each initial charge period and the further deposit of a coin for each additional overtime charge period. Deposit of the coin is made in a coin box included as part of the subscribers station equipment and capable of accepting only nickels except in the case of the Pre-pay service where the coin box has 3 slots arranged to accept nickels, dimes, and quarters. Coin subscribers, when making calls to zone and toll charge points, require the services of an operator for timing and charging, the Pre-pay subscribers depositing the required charges in nickels, dimes, and quarters at the time of calling, while all other coin subscribers are billed later. AMA subscribers may dial all local, zone, and toll charge points directly and the AMA equipment in the number 5 central office will automatically record the time and charge rate for each call. These records, after processing at an AMA accounting center produce information for periodically billing the AMA subscriber. The circuit functional steps described in the previous sections of this chapter apply strictly to calls not requiring charging and, with the additions noted in the following paragraphs will apply to messages requiring charging.

Calls from two party message rate (2MR) subscribers require that the originating register determine the party one or party two identity of the calling subscriber. Upon receipt of a signal that the call is from a 2MR line a second party test signal is included in the information passed from the line link to the marker and from the marker to the originating register during the marker dial tone job. An initial party test, made by the originating register during the marker dial tone job, must agree with the second party test performed upon completion of subscriber dialing before the register

can seize a marker for the succeeding outgoing or intra-office trunk job. During this job, the party identity is included in the information passed from the originating register to the marker where it is used to set the outgoing trunk for later charging the proper party. Upon signal that the called party has answered, the outgoing trunk will operate the message register of the calling telephone number one step, using the sleeve wire of the talking channel and the subscriber line. When the outgoing trunk is arranged for overtime charging the message register operation will be repeated at the end of each overtime period. Calls from one party message rate subscribers follow the same circuit functional steps without the party identity tests.

Calls from prepay con-first coin lines may proceed thru the marker dial tone job to connect with an originating register upon removal of the calling handset, but dial tone will not be transmitted until a coin is deposited. During the marker outgoing or intr-office trunk job the coin class of calling subscriber service will cause the marker to select a trunk arranged for coin service and having an appearance on a coin supervisory link frame (Chapter IV Sec. 12). Upon answer of the called party the coin timing feature of the outgoing or intra-office trunk starts measuring time and at the end of four and one-half minutes causes the trunk to be connected to an idle coin supervisory circuit through a crosspoint on the coin supervisory link frame. The coin supervisory circuit applies coin collect voltage and a tone to the talking wires of the channel and subscribers line which collects the calling subscribers coin and notifies him that the initial time period is near completion. The coin supervisory circuit maintains tone on the calling subscriber line for approximately one-half second and then releases. The timer continues to operate and immediately after the five minute initial interval the trunk is again associated with an idle coin supervisory circuit through another cross-point on the coin supervisory link frame, the coin supervisory circuit this time being signaled to not collect the coin but rather to only test for the presence of a second nickel for the overtime period and upon finding it to again release. This in turn resets the timer circuit which again measures off a 5 minute cycle for the overtime period similar to that just described for the initial period. If the call does not proceed a full 5 minutes after the called party has answered the coin supervisory circuit for collecting the coin will be associated with the trunk upon signal that the calling party has hung up. If the calling party abandons the call before the called party answers a coin supervisory circuit will be called in and caused to refund the coin. Under certain special conditions such as calls to zero operator, 11-X and X-11 code calls, abandoned calls, permanent signal calls, and certain trouble conditions, the originating register refunds the coin instead of having the trunk call in a coin supervisory circuit.

Normal charge calls from prepay tone-first coin lines proceed the same as calls from lines of prepay coin-first class with the exception that verification of the coin deposit is delayed by the originating register until after subscriber dialing is completed at which time the lack of a coin would prohibit the register summoning a marker for an outgoing or intra-office trunk job. Calls to zero operator may be made without depositing a coin however, and the originating register, instead of testing for a coin will apply coin return voltage on each zero call to refund any coin that may have been dropped.

Calls from AMA subscribers require that the trunks and outgoing senders used on the calls have access to the AMA tape recording equipment. Recorded upon the AMA tape is the calling and called parties' telephone numbers and the associated billing rate, information which was secured from the outgoing sender, plus the times of conversation starting and stopping, information which was secured from the trunk circuit. The AMA call proceeds through the circuit functional steps of the non-charge call given previously up to the point during the marker outgoing trunk job where information is given from the completely dialed originating register into the marker. At this point an intra-office AMA call deviates from a non-charge intra-office call in that the AMA intra-office trunk is connected to a sender, not used otherwise. Included in the information transferred to the outgoing sender by the marker will be the called office and telephone number and the calling party's line link location and class of service.

The relaying of this information, in terms of calling and called party telephone numbers, is a major function of the outgoing sender on all AMA calls and is the sole function of the outgoing sender on an AMA intra-office call. Charge functions in the trunk circuit, similar to those described previously for message rate calls are initiated upon answer of the called party and result in the trunk associating itself with the AMA tape recording equipment and entering upon the tape the time of day at which the conversation starts. A similar charge function is initiated in the trunk upon disconnection of either party and results in the trunk causing to be entered upon the tape the time of day when the conversation stops. The elapsed interval between the two time entries, combined with the rate for calls between the two offices shown on the calling and called party entry, are used later by the automatic Accounting Center equipment to bill the AMA subscriber.

Section 8. Test and Trouble Recording Facilities.

The locating of trouble in the number 5 equipment is accomplished in one of two ways: (a) test calls, directed at particular circuits and initiated in the master test frame which upon failure of the call cause the master test frame to summon the trouble recorder and make a punched card record of the call and its failure, and (b) service calls which, while being monitored by the master test frame have failed and caused the associated control or monitor circuits to summon the trouble recorder. The trouble recorder portion of the master test frame automatically reports the troubles encountered establishing the service for testing actions through the number 5 and associated AMA equipment. One master test frame is provided for each marker group and constitutes the maintenance center for the frames serving that group.

Test calls initiated at the master test frame may be directed at the markers, registers, senders, trunks, subscriber lines, number groups, and AMA equipment. Keys located upon the face of the master test frame provide the person making tests with control of the circuit to be tested and the type of test to be applied. Each test is individually started by the test man and proceeds through the master test connector frame to the desired circuits. Failure of a test call will be recognized by the associated test circuit and will cause it to connect itself through the master test connector to the trouble recording unit in which a punched card record of each failure will be made.

Automatic monitoring of the service calls handled by registers and senders is controlled by keys on the face of the master test frame. This monitoring may be performed upon originating registers, outgoing senders, and incoming registers successively in that order or may be directed to repeat upon a particular circuit or class of circuit. The monitoring operation consists of comparing the information given into a register or sender with the corresponding information given out of that sender, for instance: the dialed digits of the called office and telephone number as stored in the originating register, are compared by the monitor with the called office and telephone number as received by the marker from that register. Similarly information given from the marker to an outgoing sender is compared by the monitor with the corresponding information as outpulsed to an incoming register.

Service and test calls which a marker finds impossible to complete will cause that marker to deposit a complete record of the call on a trouble recorder card and then, in most cases, recycle and attempt to complete the call using different circuits wherever possible. Connection between the marker and trouble recorder is again made through the master test connector frame, this time upon demand from the marker.



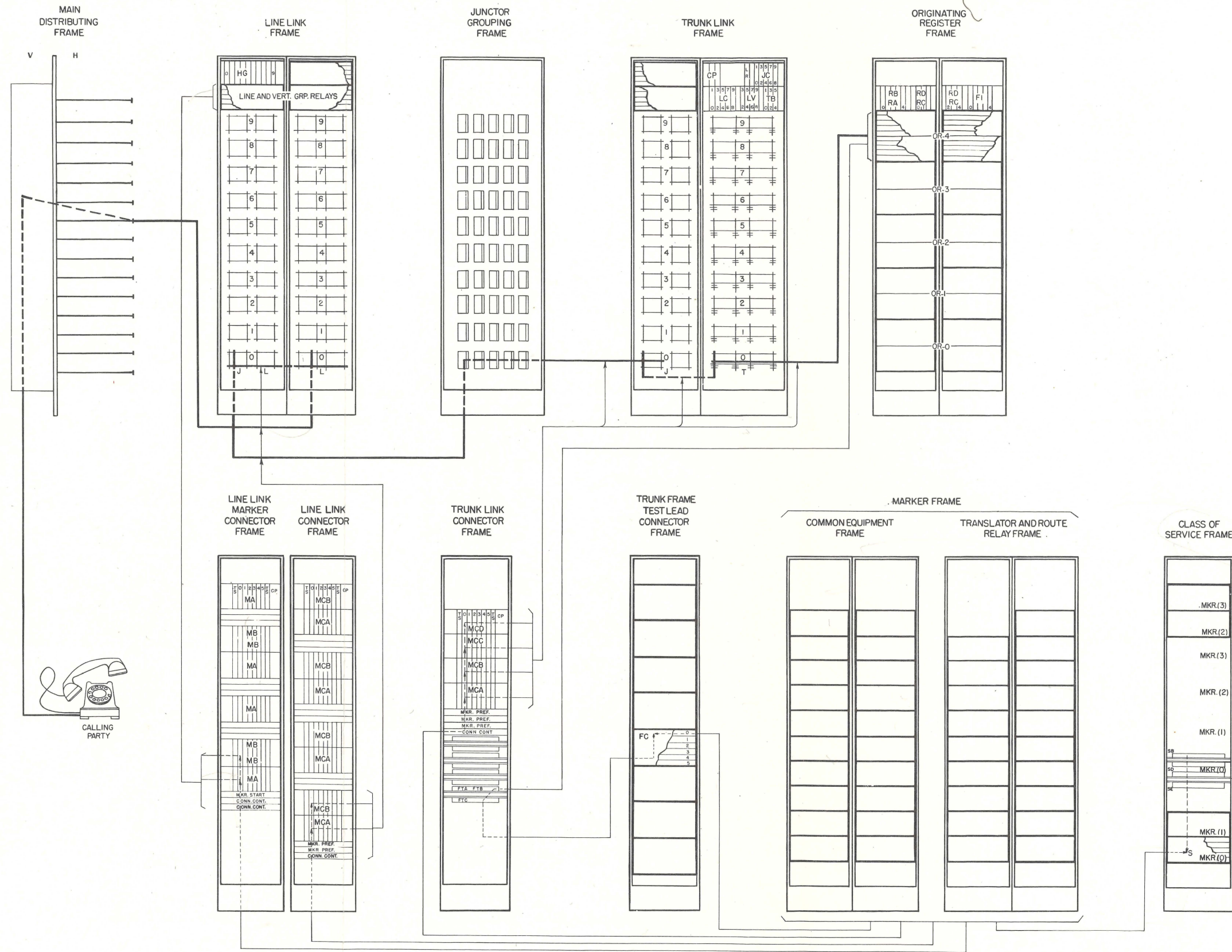

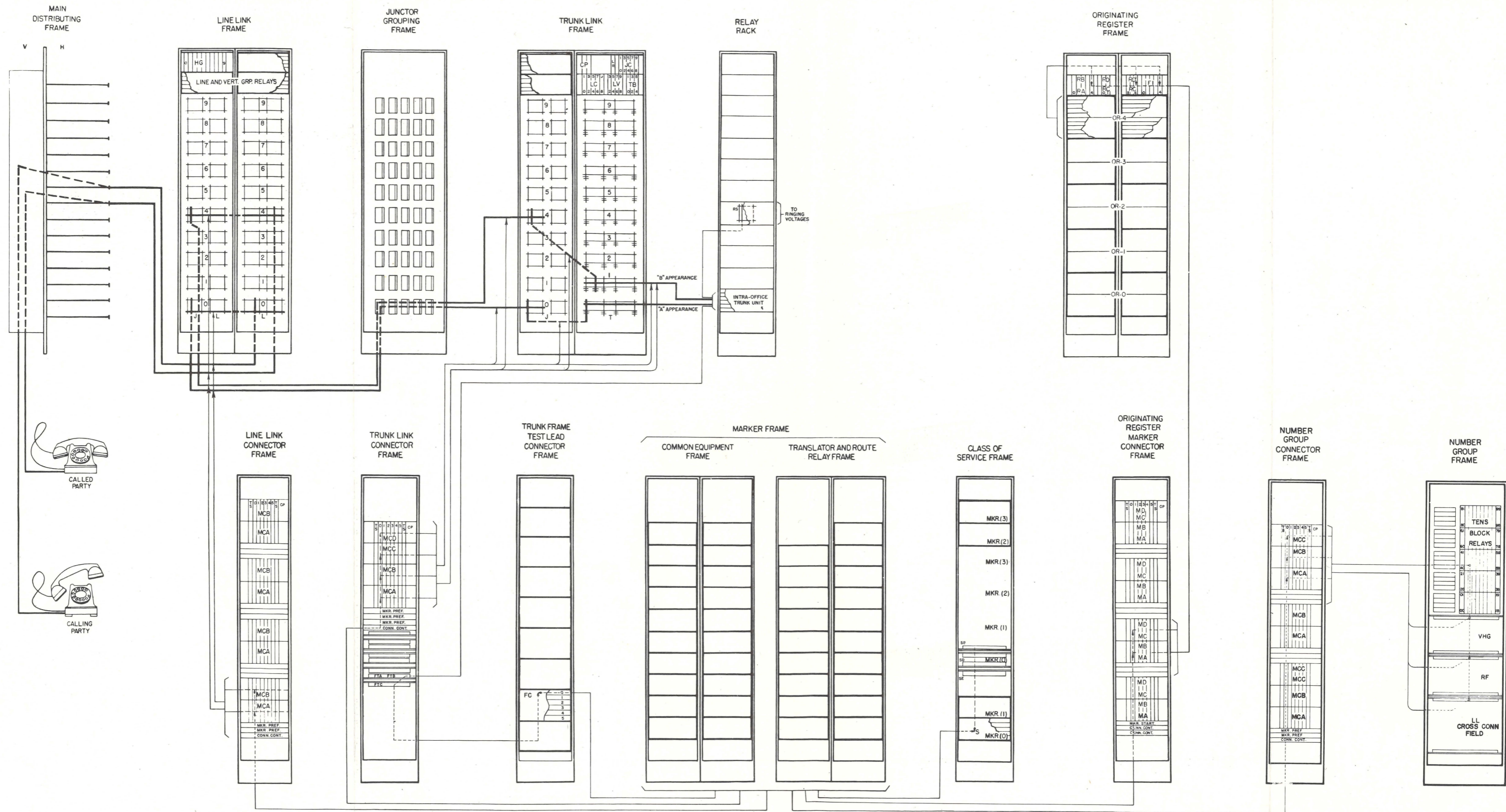



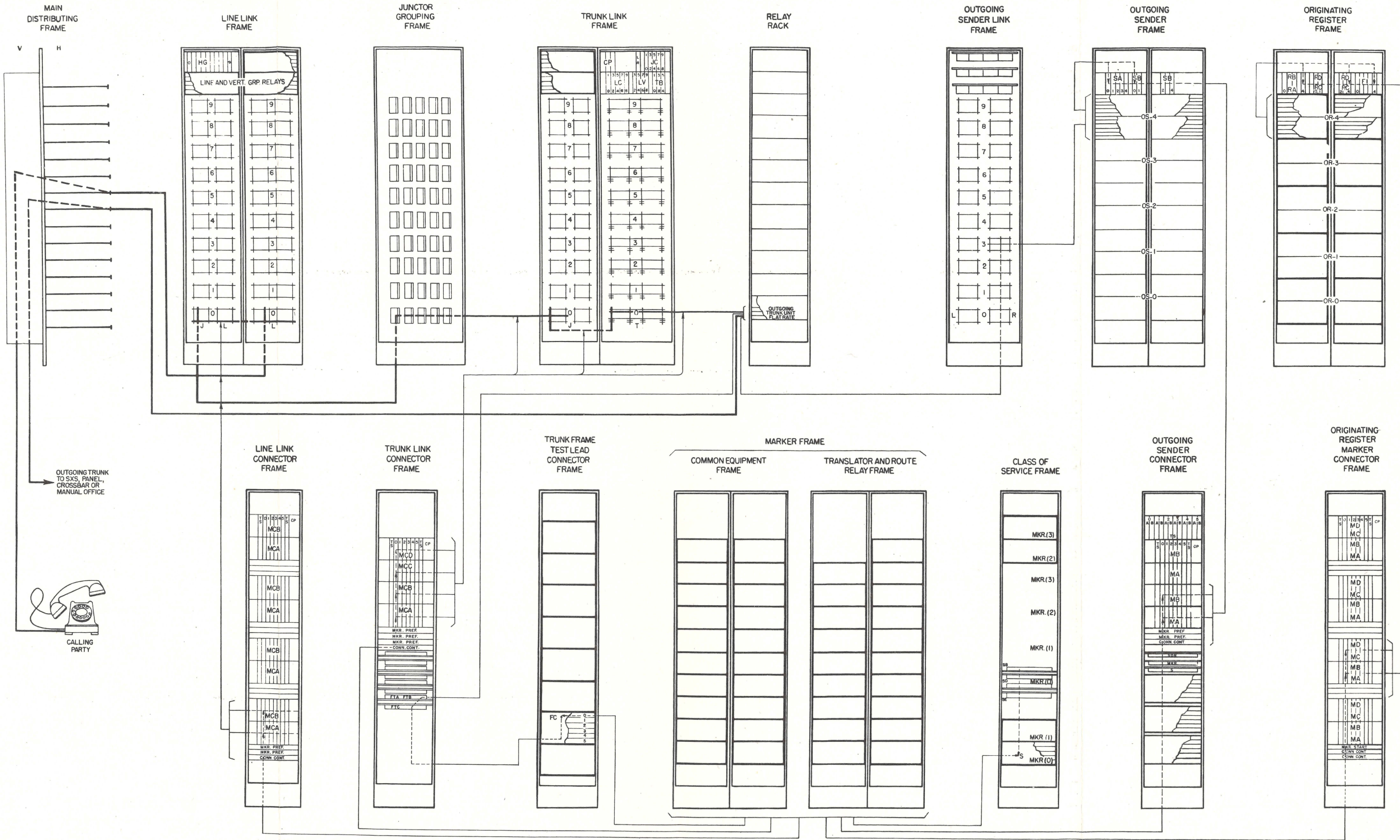

OUTGOING TRUNK  
TO SXS, PANEL,  
CROSSBAR OR  
MANUAL OFFICE



FOR TRAINING PURPOSES ONLY

**CONNECTION OF CALLING PARTY TO OUTGOING TRUNK (MARKER OUTGOING TRUNK JOB)**

WESTERN ELECTRIC COMPANY  
INCORPORATED  
HAWTHORNE WORKS  
PERSONNEL SERVICE BRANCH

DATE: 2-1-50  
DRAWN BY: A.W.B.  
SKETCH NUMBER: 72  
TRAINING DEPT: 4831

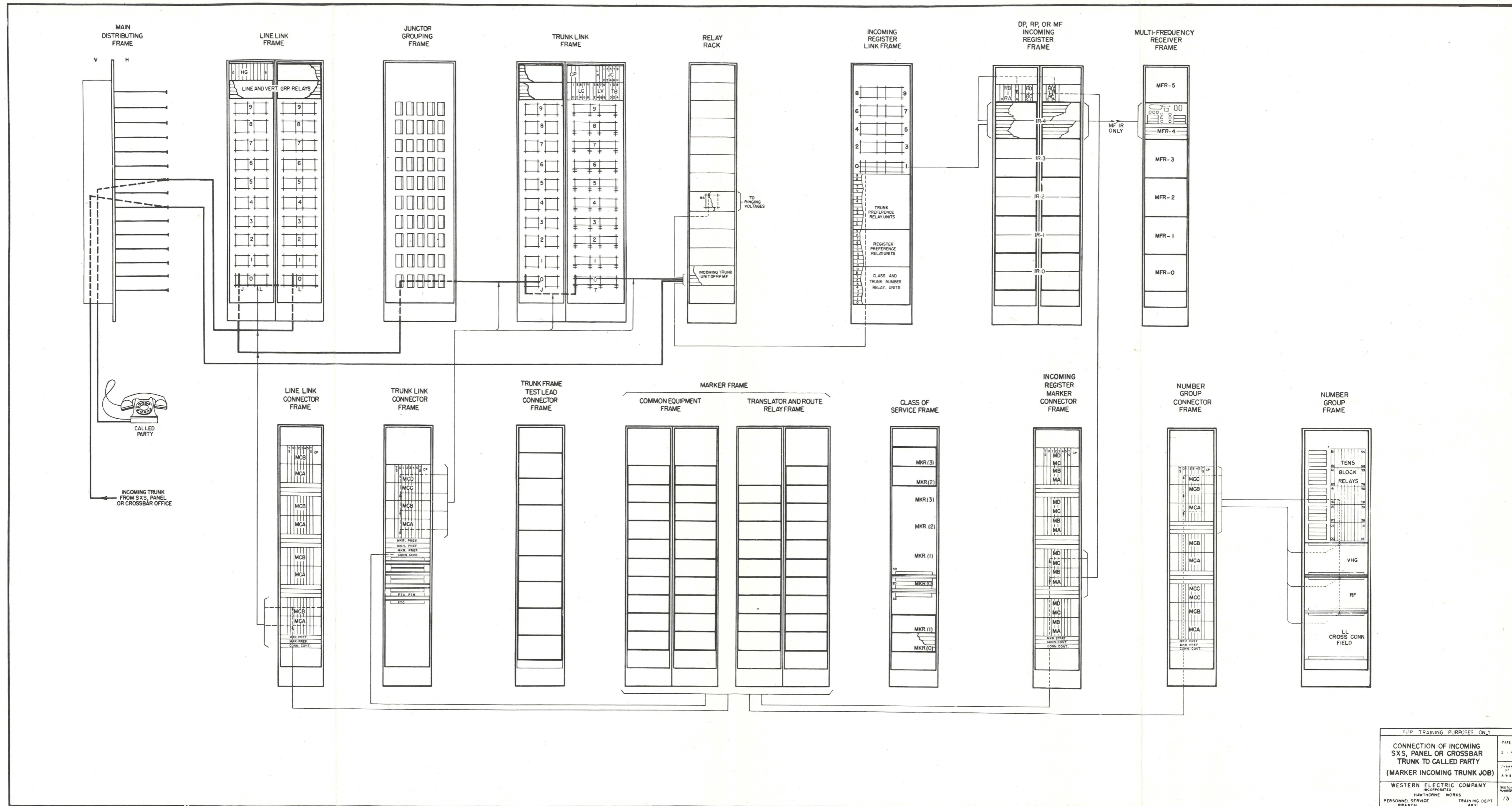

FOR TRAINING PURPOSES ONLY

CONNECTION OF INCOMING  
SXS, PANEL OR CROSSBAR  
TRUNK TO CALLED PARTY  
(MARKER INCOMING TRUNK JOB)

WESTERN ELECTRIC COMPANY  
INCORPORATED  
HAWTHORNE WORKS  
PERSONNEL SERVICE BRANCH

DATE: 2-1-50  
DRAWN BY: A.W.B.  
CHECKED BY: 73

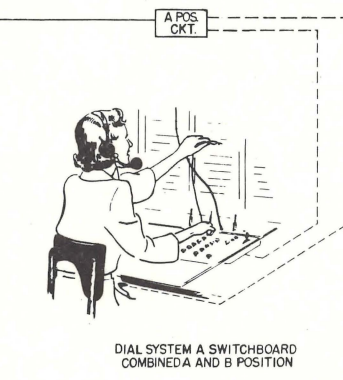
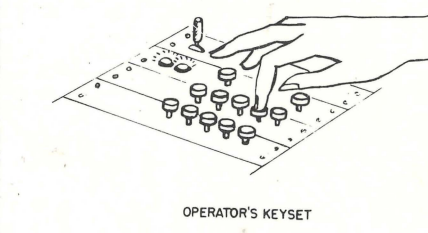
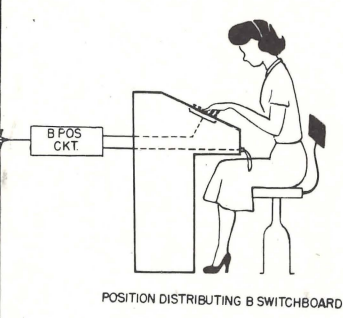
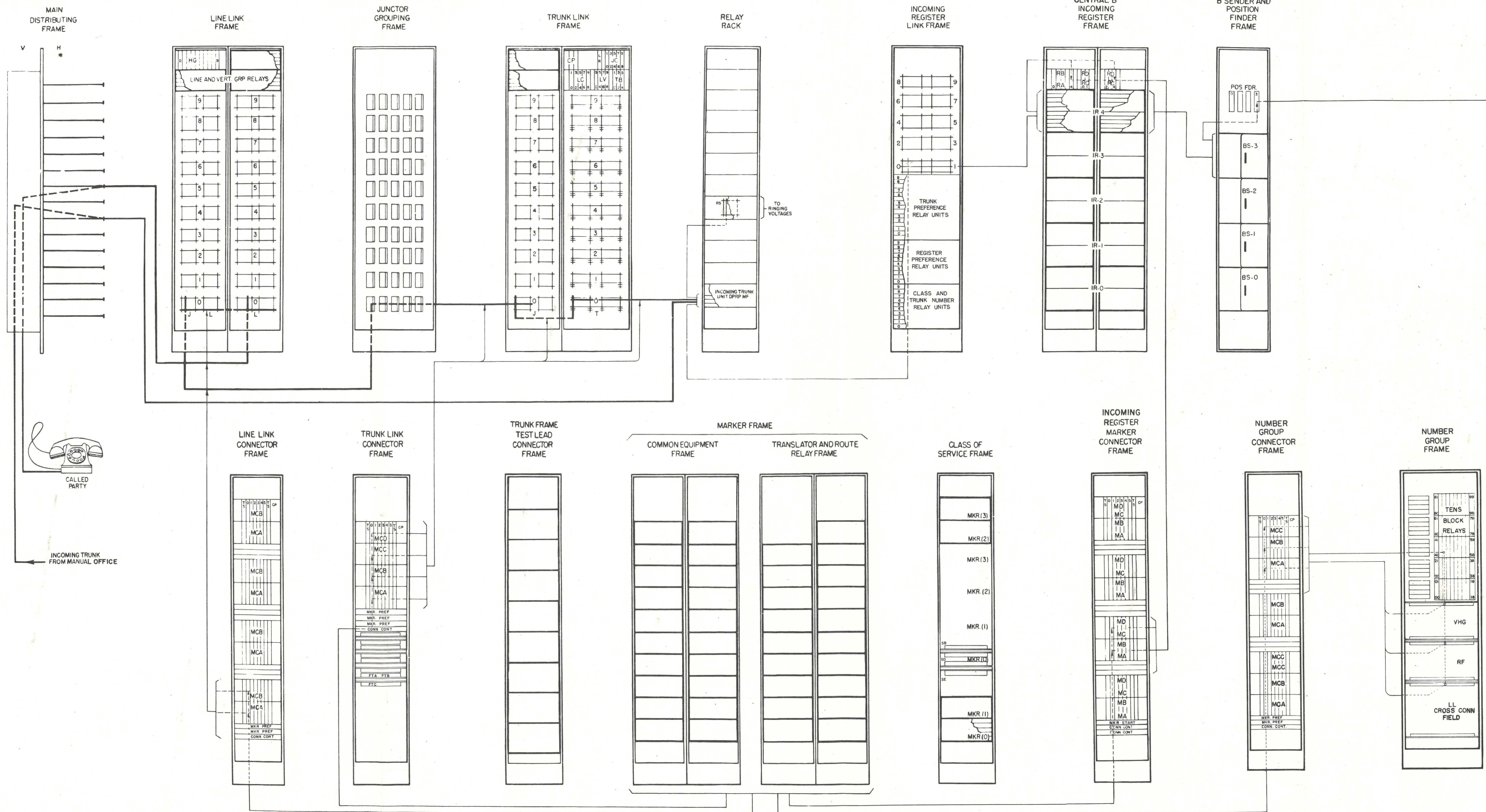

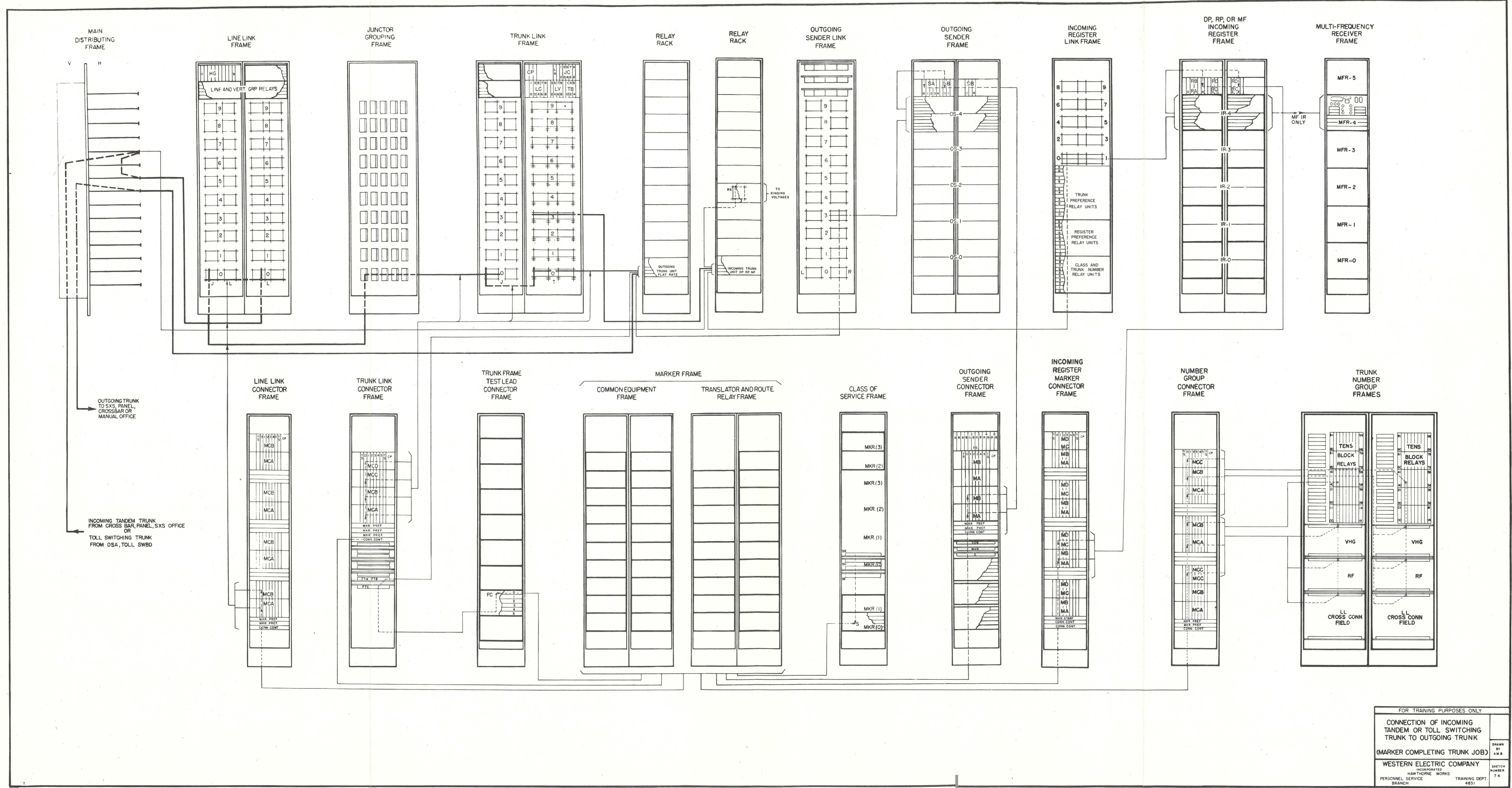

FOR TRAINING PURPOSES ONLY

CONNECTION OF INCOMING TANDEM OR TOLL SWITCHING TRUNK TO OUTGOING TRUNK

(MARKER COMPLETING TRUNK JOB)

WESTERN ELECTRIC COMPANY

INCORPORATED  
HARTFORD, CONNECTICUT

PERSONNEL SERVICE TRAINING DEPT. BRANCH 4831

DRAWN BY A.W.B.

SKETCH NUMBER 74

CHAPTER VII

POWER

Section 1. Power

The purpose of the telephone power plant is to furnish electrical energy of the required characteristics as to voltage and current, for continuous operation of the equipment and talking circuits.

The primary power source is usually a commercial (Edison) electric service from outside the central office. In order to meet the vital need of ever ready power, a local means of charging such as a Deisel Motor-Generator set is usually provided as a reserve for this service.

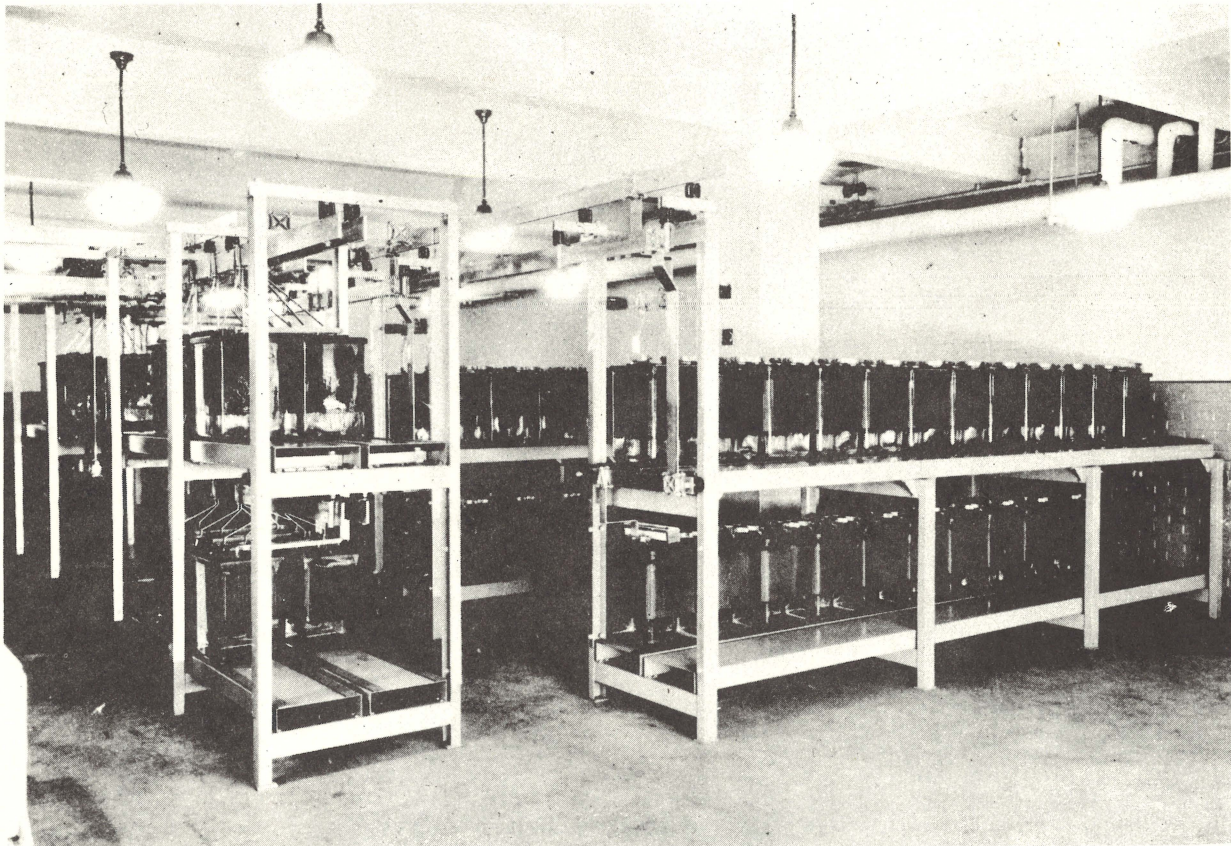

Fig. 75 - Central Office Storage Batteries

Short interruptions of service are experienced with even the best commercial power services and it is therefore necessary to provide another source which shall be available at all times to operate the central office during emergency failures of the outside service. This is accomplished by the use of a storage battery (Fig. 75) of sufficient capacity to carry the load of the office during temporary failures of the power sources, the battery being continuously connected to the circuits so that no service interruptions shall occur. The sizes of battery provided are sufficient to carry the exchange load for intervals ranging from a few hours to several days, depending upon the size of the load, and are assembled in batteries of 48 volts.

The 301C power plant (Fig. 76) is standard for crossbar number 5 central offices having current drains up to 2,000 amperes and provides facilities for modifying the commercially supplied power, which is 220 volts three phase AC, into a form suitable for charging the storage batteries. These facilities include motor-generator sets containing a 220 volt AC motor driving a 48 volt DC generator plus various dry disc and vacuum tube rectifiers, and are so operated as to continuously supply the average amount of power demanded by the central office load with momentary variations in that load being absorbed or supplied by the storage batteries.

A simplified ringing power plant, coded as the 803C and shown mounted on the tables to the lower left in (Fig. 76), is used and employs one ringing potential for both individual and party lines. A duplicate set of generators supplies the 20 cycle a-c d-c and superimposed ringing voltages and is furnished with means for automatically switching the load from one machine to the other in case of failure of the first machine. These machines also supply the dial, busy and overflow tones used.

A small 22 volt 60 cycle AC transformer supplies the power for the trunk circuit timers and the switchboard position clocks.

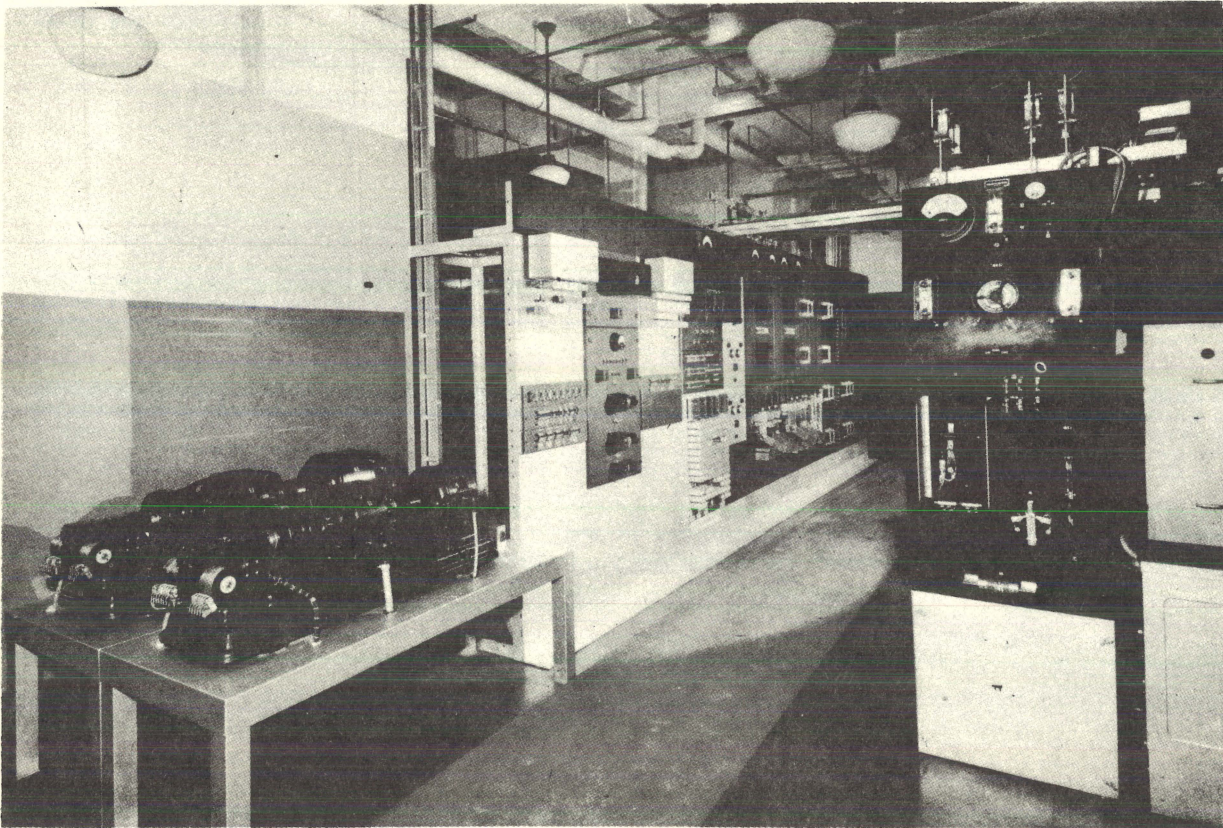

Fig. 76 - 301-C Power Plant

